

## Mini-Excavator **Zaxis27U** Specifications

Rated Engine Power		
DIN 6271, net	22.5 kW (30.6 PS)	
SAE J1349, net	23.0 kW (30.9 hp)	
Operating Weight	(Rubber shoes)	(Grouser shoes)
2-Pillar canopy version	2 780 kg	2 850 kg
4-Pillar canopy version	2 840 kg	2 910 kg
Cab version	2 900 kg	2 970 kg
Backhoe Buckets		
ISO 7451	0.04 – 0.10 m <sup>3</sup>	

*The 2- or 4-pillar canopy, or cab can be mounted on the upper-structure according to job needs and applicable regulations. The 4-pillar canopy and cab conform to TOPS (ISO 12117) and FOPS (ISO 10262, Level 1)\* requirements.*

*\* Cab requires optional top guard.*

### ■ DIMENSIONS

Unit : mm

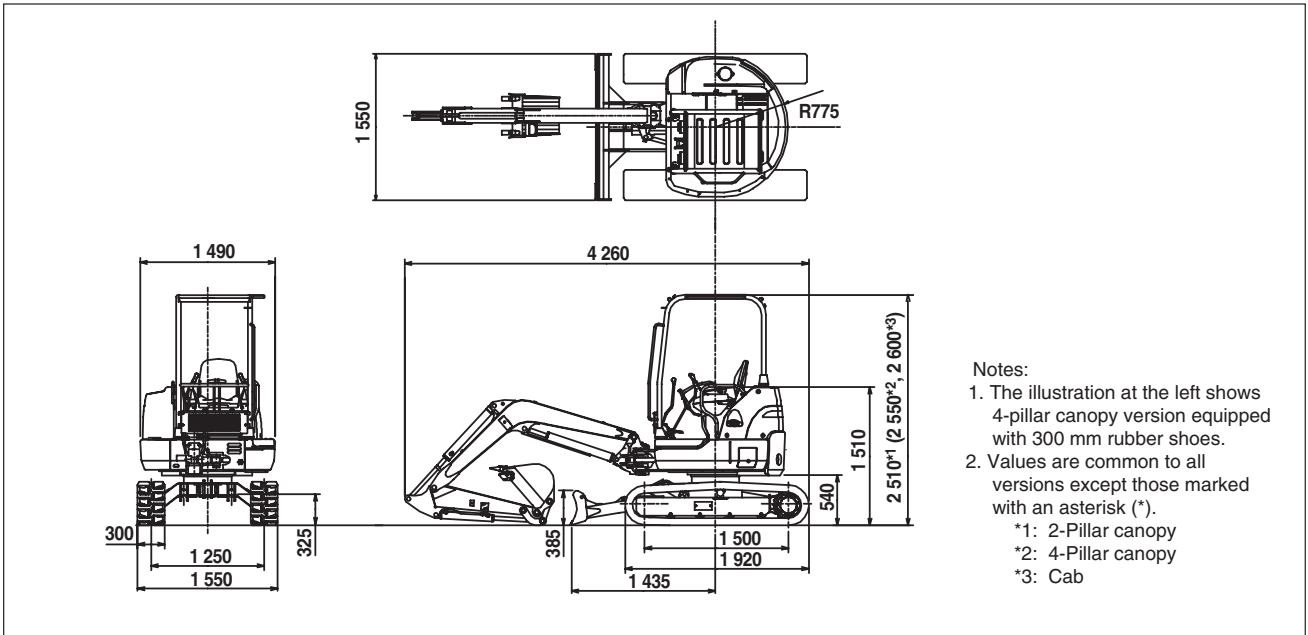

### ■ WORKING RANGES

Unit : mm

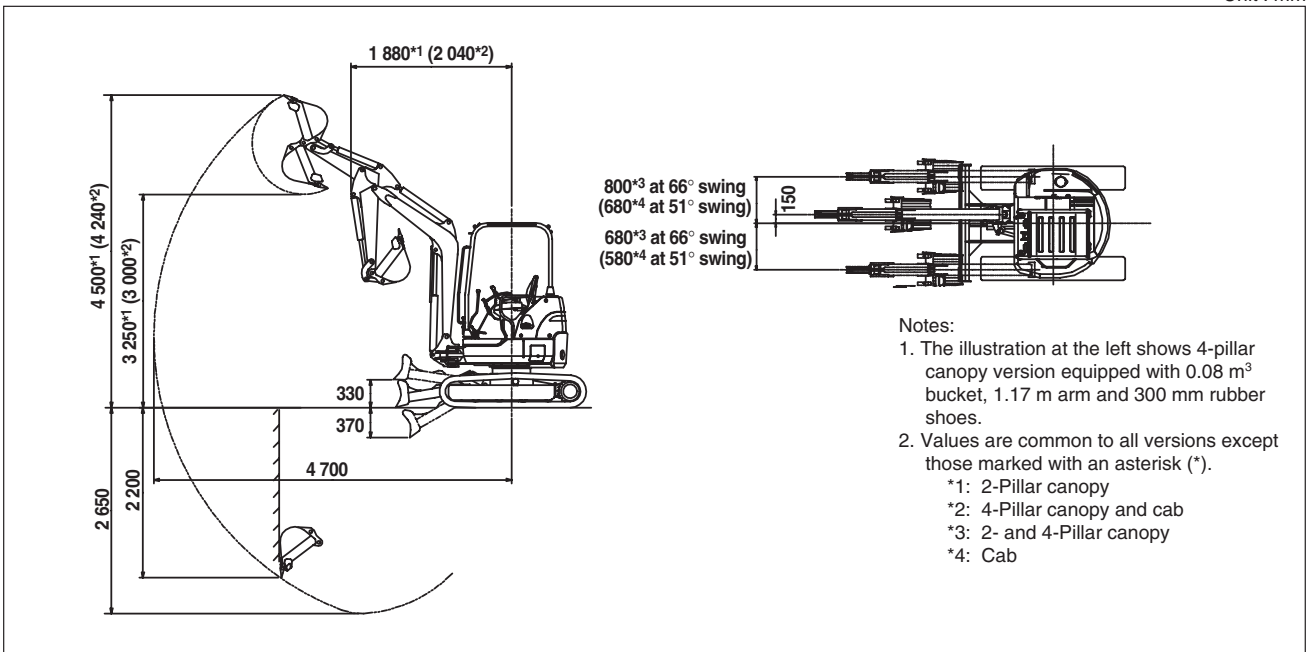

**ENGINE**

Model..... Isuzu AA-3LD2  
 Type..... Water-cooled, 4-cycle, 3-cylinder direct injection type diesel engine  
 Rated power..... 22.5 kW (30.6 PS)  
 DIN 6271, net at 2 450 min<sup>-1</sup> (rpm)  
 Rated power..... 23.0 kW (30.9 hp)  
 SAE J1349, net at 2 450 min<sup>-1</sup> (rpm)  
 Maximum torque..... 97 N·m (9.9 kgf·m)  
 at 1 800 min<sup>-1</sup> (rpm)  
 Piston displacement..... 1.496 L  
 Bore and stroke..... 83.1 mm x 92 mm  
 Battery..... 1 x 12 V, 52 Ah

**HYDRAULIC SYSTEM**

The Optimum Hydraulic System (OHS) uses three pumps for job efficiency and smooth combined operations.

Main pumps..... Two variable displacement axial piston pumps  
 Maximum oil flow..... 2 x 31 L/min  
 Third pump..... One gear pump  
 Maximum oil flow..... 16.8 L/min  
 Pilot pump..... One gear pump  
 Maximum oil flow..... 12.5 L/min

**Relief Valve Settings**

Implement circuit..... 20.6 MPa (210 kgf/cm<sup>2</sup>)  
 Swing circuit..... 20.6 MPa (210 kgf/cm<sup>2</sup>)  
 Travel circuit..... 20.6 MPa (210 kgf/cm<sup>2</sup>)  
 Pilot circuit..... 3.9 MPa (40 kgf/cm<sup>2</sup>)

**Hydraulic Cylinders**

High-strength piston rods and tubes. Cylinder cushion mechanisms provided in boom raise, arm roll-in and roll-out circuits to absorb shocks at stroke ends.

**Dimensions**

No.	Bore	Rod dia.	Stroke
Boom..... 1	75 mm	40 mm	576 mm (554 mm)
Arm..... 1	70 mm	40 mm	528 mm
Bucket..... 1	60 mm	35 mm	440 mm
Boom swing... 1	75 mm	40 mm	517 mm
Blade..... 1	85 mm	45 mm	136 mm

Note: The figure in ( ) shows the stroke for 4-pillar canopy version and cab version.

**CONTROLS**

Hydraulic pilot control levers for all operations.

**SWING MECHANISM**

High-torque, axial piston motor with planetary reduction gear. Swing circle is single-row, shear-type ball bearing with induction-hardened internal gear. Internal gear and pinion are immersed in lubricant. Swing parking brake is spring-set/hydraulic-released disc type. Swing shockless valve built in swing motor absorbs shocks when stopping swing, ensuring smooth stops.

Swing speed..... 9.0 min<sup>-1</sup> (9.0 rpm)

**UNDERCARRIAGE**

**Tracks**  
 Tractor-type undercarriage. Welded track frame using carefully selected materials. Side frame welded to track frame.

**Numbers of Rollers on Each Side**

Upper roller..... 1  
 Lower rollers..... 4

**Traction Device**

Each track driven by a high-torque, 2-speed axial piston motor through planetary reduction gear, allowing counter-rotation of the tracks. Travel shockless relief valve built in travel motor absorbs shocks when stopping travel, ensuring smooth stops.

Travel speeds (rubber shoes)..... High : 0 – 4.0 km/h  
 Low : 0 – 2.4 km/h

Travel speeds (grouser shoes)..... High : 0 – 3.9 km/h  
 Low : 0 – 2.3 km/h

Gradeability..... 30 degrees (58%) continuous

**WEIGHTS AND GROUND PRESSURE**

Equipped with 1.17 m arm and 0.08 m<sup>3</sup> (PCSA heaped) bucket

	Operating weight	Ground pressure
2-Pillar canopy version		
300 mm rubber shoes....	2 780 kg	26 kPa (0.27 kgf/cm <sup>2</sup> )
300 mm grouser shoes..	2 850 kg	27 kPa (0.28 kgf/cm <sup>2</sup> )
4-Pillar cab version		
300 mm rubber shoes....	2 840 kg	26 kPa (0.27 kgf/cm <sup>2</sup> )
300 mm grouser shoes..	2 910 kg	27 kPa (0.28 kgf/cm <sup>2</sup> )
Cab version		
300 mm rubber shoes....	2 900 kg	28 kPa (0.29 kgf/cm <sup>2</sup> )
300 mm grouser shoes..	2 970 kg	28 kPa (0.29 kgf/cm <sup>2</sup> )

**FRONT-END ATTACHMENTS**

**Backhoe Buckets**

ISO 7451 capacity	Width		No. of teeth	Weight	Use	
	Without side cutters	With side cutters			1.17 m Std. arm	1.47 m Long arm
0.04 m <sup>3</sup>	250 mm	300 mm	2	46 kg	A	A
0.05 m <sup>3</sup>	300 mm	350 mm	3	50 kg	A	A
0.06 m <sup>3</sup>	350 mm	400 mm	3	52 kg	A	A
0.07 m <sup>3</sup>	400 mm	450 mm	3	55 kg	A	A
0.08 m <sup>3</sup>	450 mm	500 mm	3	57 kg	A	B
0.09 m <sup>3</sup>	500 mm	550 mm	4	63 kg	B	B
0.10 m <sup>3</sup>	550 mm	600 mm	4	66 kg	B	C
Arm crowd force					14.8 kN (1 510 kgf)	12.9 kN (1 320 kgf)
Bucket digging force					22.6 kN (2 300 kgf)	

A: General digging  
 B: Light-duty digging  
 C: Loading

**Boom swing angle**

2- and 4-pillar canopy versions..... Left 66°, Right 66°  
 Cab version..... Left 51°, Right 51°

**STANDARD EQUIPMENT**

**Engine**

- Water-separator for engine fuel system

**Hydraulic System**

- Hydraulic pilot type control levers
- Pilot control shut-off levers
- Anti-drift valve for front attachments
- Two-speed travel system
- Swing parking brake

**Canopy (Cab)**

- Two work lights
- Heater\*\*
- Windshield wiper\*\*
- Evacuation hammer\*\*
- Seat belt\*

Note: \* : For 4-pillar canopy and cab versions  
 \*\*: For cab versions

**Undercarriage**

- 300 mm rubber shoes
- Semi-long stay blade

**Front Attachments**

- 2.1 m boom
- 1.17 m arm
- 0.08 m<sup>3</sup> hoe bucket
- Bucket clearance adjusting device
- O-ring type pin-seals for hoe bucket
- HN bushing

**OPTIONAL EQUIPMENT**

**Engine**

- Auto-idling system

**Hydraulic System**

- Hydraulic P.T.O. port
- Hydraulic piping for breaker
- Travel parking brake
- Swing motion alarm device with lamp
- Travel motion alarm device

**Canopy (Cab)**

- Heater\*\*
- Air cooler\*\*\*
- Seat belt\*
- Windshield washer\*\*\*
- Wrist rest
- 12V outlet
- Air cleaner inner element
- FOPS top guard\*\*\*
- 2-way control lever pattern selector valve (Excavator/Backhoe loader)

Notes: \* : For 2-pillar canopy version  
 \*\* : For 2- and 4-pillar canopy versions  
 \*\*\*: For cab version

**Undercarriage**

- 300 mm grouser shoes
- 400 mm triangle shoes
- 400 mm grouser shoes
- 300 mm pad crawler shoes

**Front Attachments**

- 1.47 m arm
- Backhoe buckets; see page 2.

**Counterweight**

- Weight-added counterweight (270 kg added)

**LIFTING CAPACITIES**

(Equipped with 2-pillar canopy)

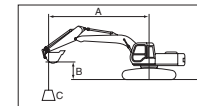

A: Load radius  
 B: Load point height  
 C: Lifting capacity

**With dozer blade above ground**

Rating over-side or 360 degrees Rating over-front Unit: 1 000 kg

Conditions	Load Point Height	Load Radius				Maximum Reach			
		2 m	3 m	4 m	meter	meter	meter		
Arm: 1.17 m	3 m		*0.48	*0.48		0.31	0.33	3.96	
	2 m		0.48	0.53	0.40	0.32	0.24	4.42	
Bucket: 0.08 m <sup>3</sup> ISO 7451	1 m		0.45	0.49	0.39	0.31	0.23	4.52	
	Ground		0.42	0.46	0.38	0.30	0.25	4.23	
Rubber shoes: 300 mm	- 1 m	0.80	0.90	0.42	0.46		0.32	0.35	3.64

**With dozer blade on ground**

Conditions	Load Point Height	Load Radius				Maximum Reach			
		2 m	3 m	4 m	meter	meter	meter		
Arm: 1.17 m	3 m		*0.48	*0.48		0.31	*0.50	3.96	
	2 m		0.48	*0.55	0.40	*0.55	0.24	*0.49	4.42
Bucket: 0.08 m <sup>3</sup> ISO 7451	1 m		0.45	*0.81	0.39	*0.60	0.23	*0.53	4.52
	Ground		0.42	*0.99	0.38	*0.65	0.25	*0.57	4.23
Rubber shoes: 300 mm	- 1 m	0.80	*1.60	0.42	*0.95		0.32	*0.57	3.64

Notes: 1. Rating are based on ISO 10567.

2. Lifting capacity does not exceed 75% of tipping load with the machine on firm, level ground or 87% full hydraulic capacity.

3. The load point is a hook (not standard equipment) located on the back of the bucket.

4. An asterisk mark (\*) indicates load limited by hydraulic capacity.



**Head office:** 5-1 Koraku 2-chome, Bunkyo-ku  
Tokyo 112-8563, Japan

**Telephone:** (03)3830-8050

**Facsimile:** (03)3830-8202

The Specifications include data that are not applicable to certain areas.  
Optional equipment may vary with territory specifications.  
Specifications are subject to change without notice.

**KS-E414P**

Printed in Japan 03.03 (TP/TP, MT<sup>3</sup>)