

HITACHI

DASH 3



ZAXIS 270LC-3

- Engine Rated Power: 188 SAE net hp (140 kW) @ 2,100 rpm
- Operating Weight: 63,425 lb. (28 770 kg)
- Backhoe Bucket: 1.74 cu. yd. (1.34 m³), 42 in. (1065 mm)

ZAXIS 270LC-3 SPECIFICATIONS

Engine

Model	Isuzu AH-4HK1XYSA-03
	meets EPA and CARB emissions non-road regulations
Type	4-cycle water-cooled, direct injection
Aspiration	turbocharged, intercooled
No. of Cylinders	4
Rated Power	
SAE J1349, net	H/P mode: 188 hp (140 kW) at 2,100 rpm (min ⁻¹)
Piston Displacement.....	317 cu. in. (5.193 L)
Bore and Stroke	4.5 in. x 4.9 in. (115 mm x 125 mm)
Electrical System	24 volt with 50-amp alternator

Hydraulic System

Main Pumps	two variable-displacement axial-piston
Maximum Flow	2 x 62.3 gpm (2 x 236 L/min.)
Pilot Pump	one gear
Maximum Flow	8.9 gpm (34 L/min.)
Pressure Setting	580 psi (4000 kPa)
System Operating Pressure	
Implement Circuits	4,980 psi (34 300 kPa)
Travel Circuits	4,980 psi (34 300 kPa)
Swing Circuits	4,700 psi (32 400 kPa)
Power Boost	5,260 psi (36 300 kPa)
Oil Filtration	one 10-micron full-flow return filter with by-pass / one pilot oil filter

Cylinders

	Bore	Rod Diameter	Stroke
Boom (2)	5.3 in. (135 mm)	3.7 in. (95 mm)	53.5 in. (1360 mm)
Arm (1).....	5.9 in. (150 mm)	4.1 in. (105 mm)	65.3 in. (1659 mm)
Bucket (1).....	5.3 in. (135 mm)	3.5 in. (90 mm)	42.1 in. (1070 mm)

Swing Mechanism

Swing Speed.....	0–12.6 rpm
Swing Torque	56,852 lb.-ft. (77 140 Nm)

Undercarriage

Carrier Rollers (per side)	2
Track Rollers (per side)	8
Shoes, Triple Semi-Grouser (per side)	49
Track Guides.....	front and center
Track Adjustment	hydraulic
Travel Speed	
Low	0–2.1 mph (0–3.3 km/h)
High.....	0–3.4 mph (0–5.5 km/h)
Drawbar Pull.....	56,074 lb. (25 435 kg)

Ground Pressure Data

Average Ground Pressure	
32-in. (800 mm) Triple Semi-Grouser Shoes (recommended for general/soft terrain).....	5.84 psi (40.3 kPa)

SAE Operating Weights

With Full Fuel Tank; 175-lb. (79 kg) Operator; 1.75-cu.-yd. (1.34 m³), 42-in. (1065 mm), 2,279-lb. (1034 kg) Bucket; 12-ft. 4-in. (3.75 m) Arm; 13,447-lb. (6100 kg) Counterweight; and 32-in. (800 mm) Triple Semi-Grouser Shoes63,425 lb. (28 770 kg)

Capacities (U.S.)

Fuel Tank	132 gal. (500 L)
Cooling System	27.5 qt. (26 L)
Engine Lubrication, Including Filter	24.3 qt. (23 L)
Hydraulic Tank	39 gal. (148 L)
Hydraulic System	63.4 gal. (240 L)
Propel Gearbox (each)	9 qt. (8.5 L)
Swing Drive	8 qt. (7.6 L)

Component Weights

Undercarriage

32-in. (800 mm) Triple Semi-Grouser Shoes	25,937 lb. (11 765 kg)
One-Piece Boom (with arm cylinder)	5,086 lb. (2307 kg)

Arm with Bucket Cylinder and Linkage

10 ft. 2 in. (3.11 m)	3,102 lb. (1407 kg)
12 ft. 4 in. (3.75 m)	3,298 lb. (1496 kg)
Boom Lift Cylinders (2) Total Weight	1,098 lb. (494 kg)
1.75-cu.-yd. (1.34 m ³), 42-in. (1065 mm) Heavy-Duty High-Capacity Bucket	2,279 lb. (1034 kg)
Counterweight	13,447 lb. (6100 kg)

Lifting Capacities

Boldface italic type indicates hydraulic-limited capacities; lightface type indicates stability-limited capacities, in lb. (kg). Ratings at bucket lift hook; machine equipped with 1.75-cu.-yd. (1.34 m³), 42-in. (1065 mm), 2,279-lb. (1034 kg) bucket; 13,447-lb. (6100 kg) counterweight; standard gauge; and situated on firm, uniform supporting surface. Total load includes weight of cables, hook, etc. Figures do not exceed 87 percent of hydraulic capacities or 75 percent of weight needed to tip machine. All lift capacities are based on SAE J1097.

Load Point Height	10 ft. (3.05 m)		15 ft. (4.57 m)		20 ft. (6.10 m)		25 ft. (7.62 m)		30 ft. (9.15 m)	
	Over Front	Over Side	Over Front	Over Side	Over Front	Over Side	Over Front	Over Side	Over Front	Over Side
<i>With 12-ft. 4-in. (3.75 m) arm and 32-in. (800 mm) triple semi-grouser shoes</i>										
25 ft. (7.62 m)							8,490 (3851)	8,490 (3851)		
20 ft. (6.10 m)							8,629 (3914)	8,629 (3914)	5,984 (2714)	5,984 (2714)
15 ft. (4.57 m)							9,676 (4389)	9,676 (4389)	9,609 (4359)	7,937 (3600)
10 ft. (3.05 m)			17,039 (7729)	17,039 (7729)	13,189 (5982)	13,189 (5982)	11,405 (5173)	10,668 (4839)	10,524 (4774)	7,680 (3484)
5 ft. (1.52 m)			24,377 (11 057)	22,290 (10 111)	16,795 (7618)	14,398 (6531)	13,401 (6079)	10,091 (4577)	11,626 (5274)	7,371 (3343)
Ground Line			28,866 (13 094)	20,936 (9497)	19,727 (8948)	13,562 (6152)	15,195 (6892)	9,601 (4355)	12,245 (5554)	7,096 (3219)
-5 ft. (-1.52 m)	15,885 (7205)	15,885 (7205)	30,355 (13 769)	20,481 (9290)	21,412 (9712)	13,102 (5943)	16,083 (7295)	9,284 (4211)	12,055 (5468)	6,922 (3140)
-10 ft. (-3.05 m)	22,504 (10 208)	22,504 (10 208)	29,877 (13 552)	20,489 (9294)	21,738 (9860)	12,972 (5884)	15,965 (7242)	9,178 (4163)	10,392 (4714)	6,920 (3139)
-15 ft. (-4.57 m)	30,876 (14 005)	30,876 (14 005)	27,577 (12 509)	20,821 (9444)	20,489 (9294)	13,131 (5956)	15,518 (7039)	9,328 (4231)		
-20 ft. (-6.10 m)	30,941 (14 035)	30,941 (14 035)	22,517 (10 214)	21,537 (9769)	16,452 (7463)	13,673 (6202)				
<i>With 10-ft. 2-in. (3.11 m) arm and 32-in. (800 mm) triple semi-grouser shoes</i>										
20 ft. (6.10 m)							10,107 (4585)	10,107 (4585)		
15 ft. (4.57 m)					11,760 (5334)	11,760 (5334)	10,993 (4986)	10,981 (4981)	8,349 (3787)	7,778 (3528)
10 ft. (3.05 m)			20,484 (9291)	20,484 (9291)	14,959 (6785)	14,959 (6785)	12,603 (5717)	10,494 (4760)	11,531 (5230)	7,587 (3441)
5 ft. (1.52 m)			27,306 (12 386)	21,575 (9786)	18,319 (8309)	14,121 (6405)	14,426 (6544)	9,976 (4525)	12,445 (5645)	7,332 (3326)
Ground Line			28,596 (12 971)	20,733 (9404)	20,773 (9423)	13,441 (6097)	15,959 (7239)	9,564 (4338)	12,256 (5559)	7,117 (3228)
-5 ft. (-1.52 m)	14,458 (6558)	14,458 (6558)	30,272 (13 731)	20,588 (9339)	21,875 (9922)	13,133 (5957)	16,127 (7315)	9,337 (4235)	12,156 (5514)	7,026 (3187)
-10 ft. (-3.05 m)	23,292 (10 565)	23,292 (10 565)	29,066 (13 184)	20,762 (9418)	21,566 (9782)	13,130 (5956)	16,121 (7312)	9,332 (4233)		
-15 ft. (-4.57 m)	29,503 (13 382)	29,503 (13 382)	25,803 (11 704)	21,225 (9628)	19,419 (8808)	13,422 (6088)				

Buckets

A full line of buckets is offered to meet a wide variety of applications. Digging forces are with power boost. Tooth selection includes either the John Deere Fanggs®, Standard, Tiger, Twin Tiger, Abrasion panel, or Flare tooth, or the ESCO (Vertalok) Standard, Tiger, Twin Tiger, or Flare tooth. Replaceable cutting edges are available through John Deere parts. Optional side cutters add 6 inches (150 mm) to bucket widths.

Type Bucket	Bucket Width		Bucket Capacity*		Weight		Bucket Dig Force		Arm Dig Force 10 ft. 2 in. (3.11 m)		Arm Dig Force 12 ft. 4 in. (3.75 m)		Bucket Tip Radius		No. Teeth
	in.	mm	cu. yd.	m ³	lb.	kg	lb.	kN	lb.	kN	lb.	kN	in.	mm	
Heavy-Duty Plate Lip	42	1065	1.38	1.06	2,195	996	41,476	184.5	30,510	135.7	26,741	118.9	56.5	1435	5
	48	1220	1.60	1.22	2,359	1070	41,476	184.5	30,510	135.7	26,741	118.9	56.5	1435	6
	54	1370	1.82	1.39	2,507	1137	41,476	184.5	30,510	135.7	26,741	118.9	56.5	1435	6
Heavy-Duty High Capacity	24	610	0.92	0.70	1,765	801	37,480	166.7	29,518	131.3	25,979	115.6	62.5	1588	3
	30	760	1.20	0.92	2,010	912	37,480	166.7	29,518	131.3	25,979	115.6	62.5	1588	4
	36	915	1.48	1.13	2,133	968	37,480	166.7	29,518	131.3	25,979	115.6	62.5	1588	4
	42	1065	1.75	1.34	2,279	1034	37,480	166.7	29,518	131.3	25,979	115.6	62.5	1588	5
	48	1200	2.03	1.55	2,505	1136	37,480	166.7	29,518	131.3	25,979	115.6	62.5	1588	6
Severe-Duty Plate Lip	30	760	0.95	0.73	2,080	943	41,476	184.5	30,510	135.7	26,741	118.9	56.5	1435	4
	36	915	1.16	0.89	2,179	988	41,476	184.5	30,510	135.7	26,741	118.9	56.5	1435	4
	42	1065	1.38	1.06	2,345	1064	41,476	184.5	30,510	135.7	26,741	118.9	56.5	1435	5
Ditching	60	1525	1.34	1.02	1,562	709	49,848	221.7	32,225	143.3	28,044	124.7	47.0	1194	0

*All capacities are SAE heaped ratings and with side cutters.

Bucket Selection Guide*

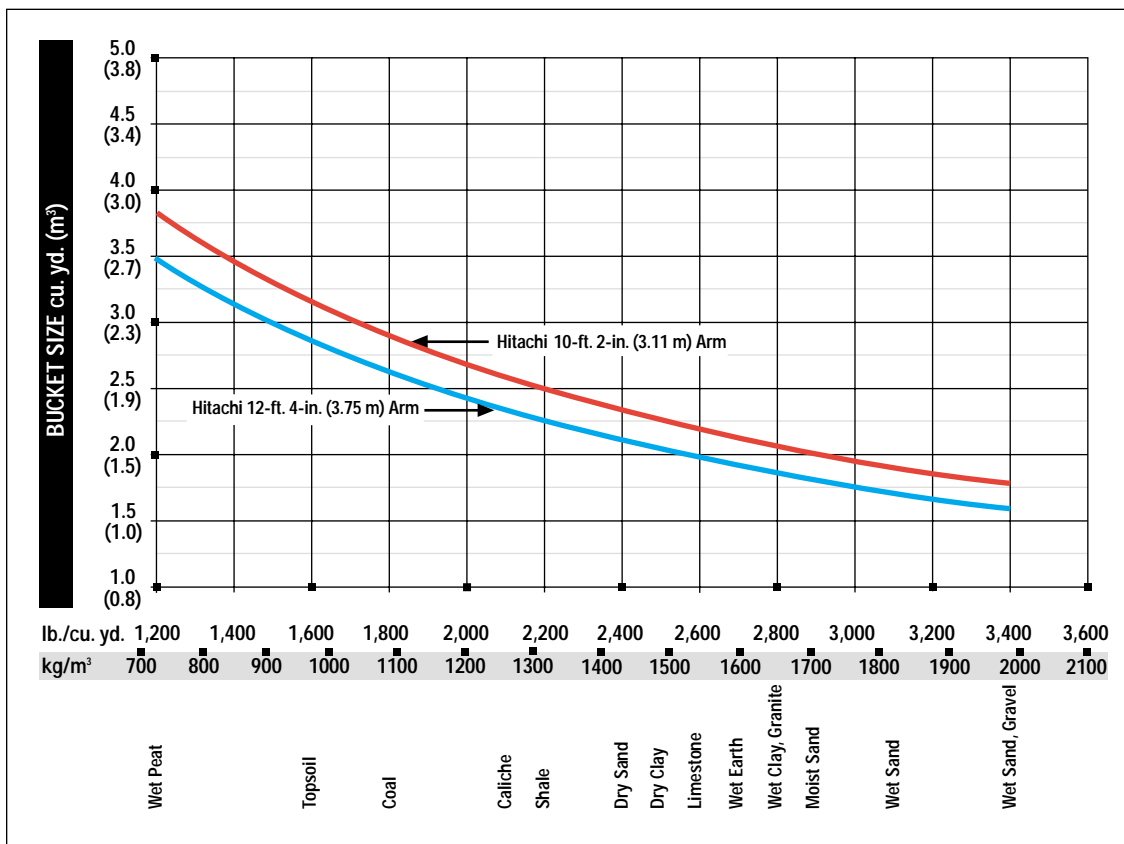

*Contact your Hitachi dealer for optimum bucket and attachment selections. These recommendations are for general conditions and average use. Does not include optional equipment such as thumbs or couplers. Larger buckets may be possible when using light materials, for flat and level operations, less compacted materials, and volume loading applications such as mass excavation applications in ideal conditions. Smaller buckets are recommended for adverse conditions such as off-level applications, rocks, and uneven surfaces. Bucket capacity indicated is SAE heaped.

Dimensions

A	10-ft. 2-in. (3.11 m) arm.....	10 ft. 5 in. (3.17 m)
	12-ft. 4-in. (3.75 m) arm.....	11 ft. 0 in. (3.35 m)
B	10-ft. 2-in. (3.11 m) arm.....	33 ft. 11 in. (10.34 m)
	12-ft. 4-in. (3.75 m) arm.....	35 ft. 3 in. (10.74 m)

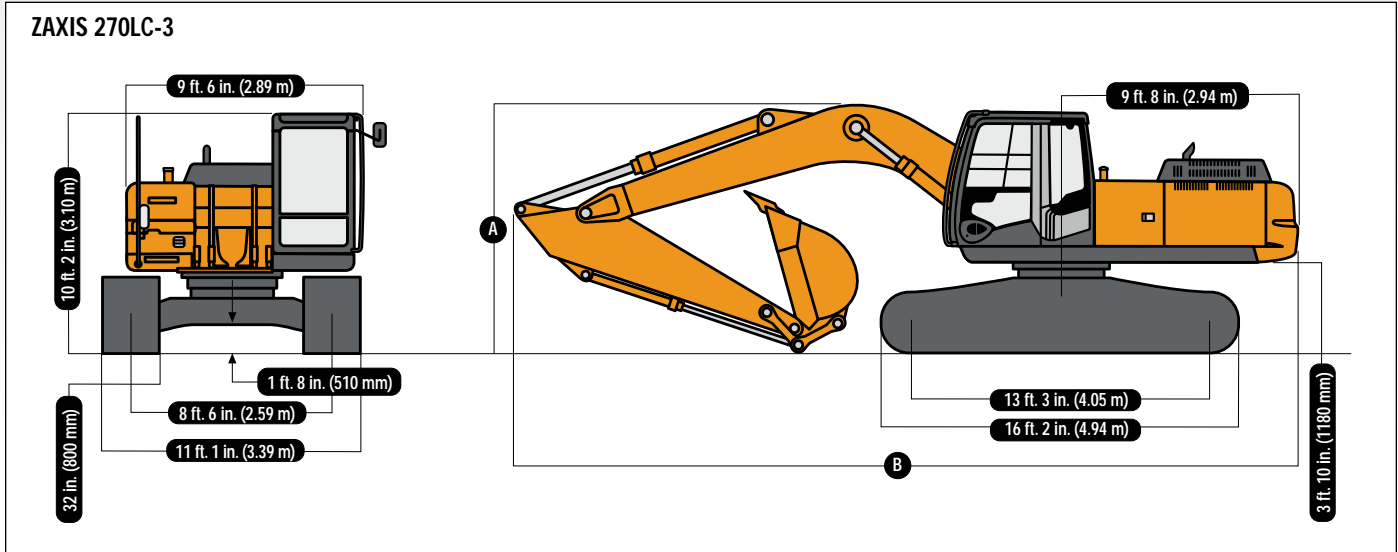

Operating Information

	Arm Length 10 ft. 2 in. (3.11 m)	Arm Length 12 ft. 4 in. (3.75 m)
Arm Force with 32-in. (800 mm) Triple Semi-Grouser Shoes*	29,518 lb. (131.3 kN)	25,979 lb. (115.55 kN)
Bucket Digging Force with 32-in. (800 mm) Triple Semi-Grouser Shoes*	37,480 lb. (166.7 kN)	37,480 lb. (166.7 kN)
Lifting Capacity Over Front @ Ground Level		
20-ft. (6.1 m) Reach*	20,773 lb. (9423 kg)	19,727 lb. (8948 kg)
A Maximum Reach	35 ft. 3 in. (10.74 m)	37 ft. 1 in. (11.30 m)
A' Maximum Reach @ Ground Level	34 ft. 7 in. (10.55 m)	36 ft. 6 in. (11.12 m)
B Maximum Digging Depth	23 ft. 10 in. (7.26 m)	25 ft. 11 in. (7.91 m)
B' Maximum Digging Depth		
@ 8-ft. (2.44 m) Flat Bottom	23 ft. 2 in. (7.05 m)	25 ft. 8 in. (7.72 m)
C Maximum Cutting Height	32 ft. 10 in. (10.01 m)	34 ft. 4 in. (10.46 m)
D Maximum Dumping Height	23 ft. 2 in. (7.07 m)	24 ft. 7 in. (7.49 m)
E Minimum Swing Radius	13 ft. 7 in. (4.41 m)	12 ft. 9 in. (3.89 m)
F Maximum Vertical Wall	20 ft. 1 in. (6.11 m)	23 ft. 1 in. (7.03 m)
G Tail Swing Radius	9 ft. 8 in. (2.94 m)	9 ft. 8 in. (2.94 m)

*Digging forces and lift capacities with power boost.

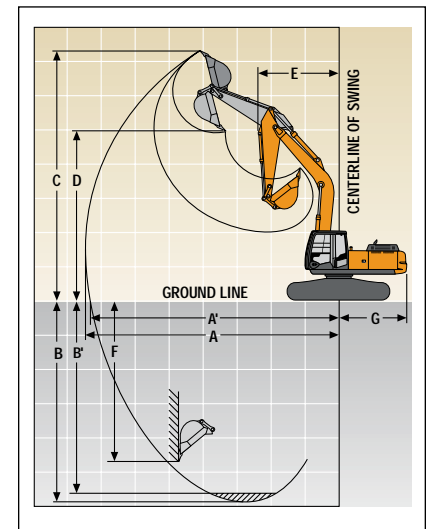

Equipment

Key ● Standard Equipment ▲ Optional or Special Equipment

Engine

- H/P mode control
- E mode control
- 50 A alternator
- Dry-type air filter with evacuator valve (with air filter restriction switch for monitor)
- Cartridge-type engine oil filter
- Cartridge-type fuel double filters
- Air cleaner double filters
- Radiator, oil cooler and intercooler with dust protective net
- Radiator reserve tank
- Fan guard
- Isolation-mounted engine
- Auto-idle system
- Fuel cooler
- Electrical fuel feed pump
- Engine oil drain coupler

Hydraulic System

- Reduced-drift valve for boom down, arm in
- Auxiliary hydraulic valve section
- Spring-applied, hydraulically released automatic swing brake
- Auxiliary hydraulic-flow adjustments through monitor
- Auto power lift
- 5,000-hour hydraulic-oil-change interval
- Hydraulic-oil-sampling valve
- ▲ Auxiliary hydraulic lines
- ▲ Auxiliary pilot and electric controls
- ▲ Hydraulic filter restriction indicator kit
- ▲ Load-lowering control device
- ▲ Single-pedal propel control
- ▲ Control pattern change valve

Undercarriage

- Planetary drive with axial piston motors
- Propel motor shields
- Spring-applied, hydraulically released automatic propel brake
- Track guides, front idler and center
- Triple semi-grouser shoes, 32 in. (800 mm)
- Two-speed propel with automatic shift
- Upper carrier rollers (2)
- Sealed and lubricated track chain

Upperstructure

- Right- and left-hand mirrors
- Vandal locks with ignition key: Cab door / Fuel cap / Service doors / Toolbox
- Debris-screening side panel
- Remote-mounted engine oil and fuel filters

Front Attachments

- Centralized lubrication system
- Dirt seals on all bucket pins
- Less boom and arm
- Oil-impregnated bushings
- Reinforced resin thrust plates
- Tungsten carbide thermal coating on arm-to-bucket joint
- ▲ Arm, 10 ft. 2 in. (3.11 m)
- ▲ Arm, 12 ft. 4 in. (3.75 m)
- ▲ Attachment quick-couplers
- ▲ Boom cylinder with plumbung to mainframe for less boom and arm
- ▲ Buckets: Ditching / Heavy duty / Heavy-duty high capacity / Severe-duty plate lip / Side cutters and teeth
- ▲ Material clamps
- ▲ Super-long fronts

Operator's Station

- Adjustable independent control positions (levers-to-seat, seat-to-pedals)
- AM/FM radio
- Auto climate control/air conditioner, 20,000 Btu/hr. (5.9 kW) with heater and pressurizer
- Built-in Operator's Manual storage compartment and manual
- Cell-phone power outlet, 12 volt, 60 watt, 5 amp
- Coat hook
- Deluxe suspension cloth seat with 4-in. (100 mm) adjustable armrests
- Floor mat
- Front windshield wiper with intermittent speeds
- Gauges (illuminated): Engine coolant / Fuel
- Horn, electric
- Hourmeter, electric
- Hydraulic shutoff lever, all controls
- Hydraulic warm-up control
- Interior light

- Large cup holder
- Machine Information Center (MIC)
- Mode selectors (illuminated): Power modes – three / Travel modes – two with automatic shift / Work mode – one
- Multifunction, color LCD monitor with: Diagnostic capability / Multiple-language capabilities / Maintenance tracking / Clock / Theft-deterrent system / System monitoring with alarm features: Auto-idle indicator, engine air cleaner restriction indicator light, engine check, engine coolant temperature indicator light with audible alarm, engine oil pressure indicator light with audible alarm, low-alternator-charge indicator light, low-fuel indicator light, fault code alert indicator, fuel-rate display, wiper-mode indicator, work-lights-on indicator, and work-mode indicator
- ▲ Monitor system with alarm features: Hydraulic oil filter restriction indicator light
- Motion alarm with cancel switch (conforms to SAE J994)
- Power-boost switch on right console lever
- Auxiliary hydraulic control switches in right console lever
- Propel pedals and levers
- SAE two-lever control pattern
- Seat belt, 2 in. (51 mm), retractable
- ▲ Seat belt, 3 in. (76 mm), non-retractable
- Tinted glass
- Transparent tinted overhead hatch
- Hot/cold beverage compartment
- ▲ Air-suspension heated seat
- ▲ 24- to 12-volt D.C. radio convertors, 10 amp
- ▲ Circulation fan
- ▲ Protection screens for cab front, rear, and side
- ▲ Window vandal protection covers

Electrical

- 50-amp alternator
- Blade-type multi-fused circuits
- Positive terminal battery covers
- ▲ Cab extension wiring harness

Lights

- Work lights: Halogen / One mounted on boom / One mounted on frame

Control Owning and Operating Costs

Customer Personal Service (CPS) is part of Hitachi's proactive, fix-before-fail strategy on machine maintenance that will help control costs, increase profits, and reduce stress. Included in this comprehensive lineup of ongoing programs and services are:

Fluid analysis program – tells you what's going on inside all of your machine's major components so you'll know if there's a problem before you see a decline in performance. Fluid analysis is included in most extended coverage and preventive-maintenance agreements.

Preventive Maintenance (PM) agreements – give you a fixed cost for maintaining a machine for a given period of time. They also help you avoid downtime by ensuring that critical maintenance work gets done right and on schedule. On-site preventive maintenance service performed where and when you need it helps protect you from the expense of catastrophic failures and lets you avoid waste-disposal hassles.

Extended coverage – gives you a fixed cost for machine repairs for a given period of time so you can effectively manage expenses. Whether you work in a severe-service setting, or you just want to spread the risk

of doing business, this is a great way to custom-fit coverage to your operation. An extended coverage contract also travels well because it's backed by the company and is honored by all Hitachi dealers.

Customer Support Advisors (CSAs) – the CSA program lends a personal quality to Customer Personal Service (CPS). Certified CSAs have the knowledge and skills for helping make important decisions on machine maintenance and repair. Their mission is to help you implement a plan that's right for your business and take the burden of machine maintenance off your shoulders.

Net engine power is with standard equipment including air cleaner, exhaust system, alternator, and cooling fan, at standard conditions per SAE J1349 and DIN 6270B, using No. 2-D fuel at 35 API gravity. No derating is required up to 10,000-ft. (3050 m) altitude. Gross power is without cooling fan. Specifications and design subject to change without notice. Wherever applicable, specifications are in accordance with SAE standards. Except where otherwise noted, these specifications are based on a unit with 42-in. (1065 mm) bucket, 32-in. (800 mm) triple semi-grouser shoes, 13,447 lb. (6100 kg) counterweight, full fuel tank, and 175 lb. (79 kg) operator.