

HITACHI

SuperEX **EX1200**

- Engine Gross Power 510 kW (684 hp)
- Operating Weight EX1200-5C
 - Backhoe: 108 000 kg (238 100 lb)
 - BE-front: 109 000 kg (240 300 lb)
 - Loading Shovel: 111 000 kg (244 800 lb)
- Backhoe Bucket PCSA (1:1) Heaped: 3.0—7.1 m³ (3.92—9.29 yd³)
CECE (2:1) Heaped: 2.7—6.4 m³
- Loading Shovel Bucket PCSA (2:1) Heaped: 5.9—6.5 m³ (7.7—8.5 yd³)

Specifications

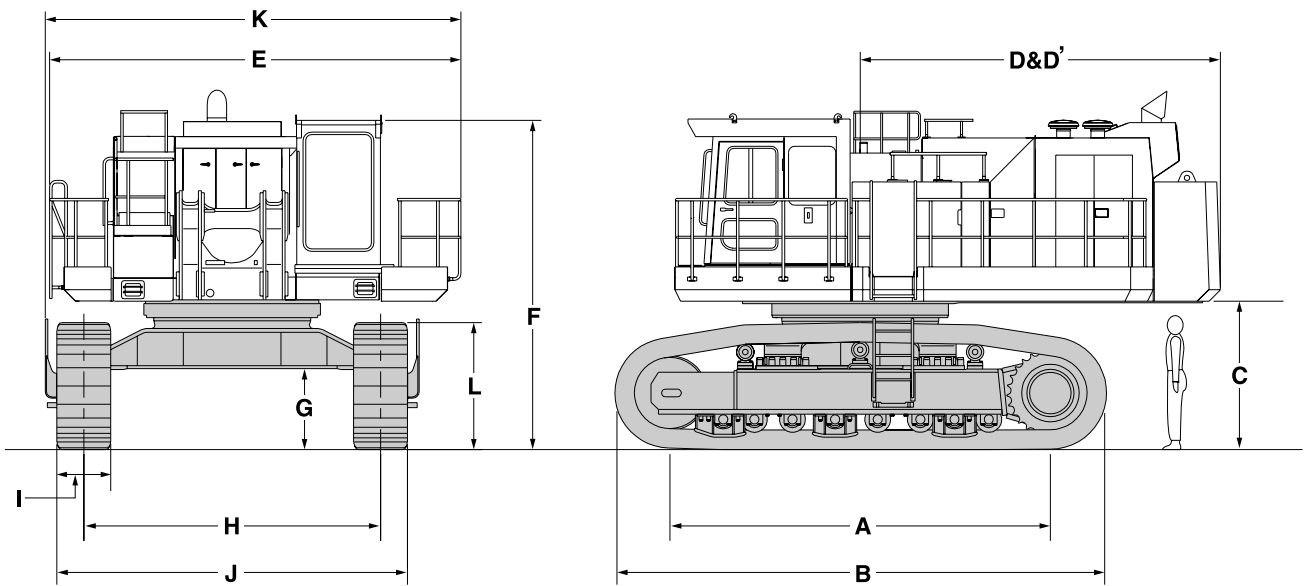

A	Distance between tumblers	5 000 mm (16'5")	
B	Undercarriage length	6 410 mm (21'0")	
C	Counterweight clearance	1 790 mm (5'10")	
D	Rear-end swing radius	4 850 mm (15'11")	
D'	Rear-end length	4 740 mm (15'7")	
E	Overall width of upperstructure	5 380 mm (17'8")	
F	Overall height of cab	Backhoe	4 320 mm (14'2")
		Loading shovel	5 410 mm (17'9")
G	Min. ground clearance	990 mm (3'3")	
H	Track gauge	3 900 mm (12'10")	
I	Track shoe width	710 mm (28")	900 mm (35")
J	Undercarriage width	4 610 mm (15'1")	4 800 mm (15'9")
K	Overall width	5 430 mm (17'10")	
L	Track height	1 570 mm (5'2")	

ENGINE

Model Hitachi S6R-Y2TAA-2
 Type Water-cooled, 4-cycle, 6-cylinder
 in line, turbo-charged direct injection
 chamber-type diesel engine.

Rated power
 DIN 6271, net 482 kW (655 PS)
 at 1 650 min⁻¹ (rpm)
 SAE J1349, net 482 kW (646 hp)
 at 1 650 min⁻¹ (rpm)
 SAE J1995, gross 510 kW (684 hp)
 at 1 650 min⁻¹ (rpm)
 Maximum torque 3 326 N•m
 (339 kgf•m, 2 453 lbf•ft)
 at 1 200 min⁻¹ (rpm)
 Piston displacement 24.5 L (1 495 in³)
 Bore and stroke 170 mm x 180 mm
 (6.7" x 7.1")
 Starting system 24 V electric motor
 Batteries 2 x 12V , 2 x 220 AH

HYDRAULIC SYSTEM

Hitachi's ETS (Electronic Total control System) can achieve maximum job efficiency by reducing fuel consumption and noise levels, while maximizing productivity through the optimization of engine-pump functions with excellent controllability increasing operator comfort.

- E-P Control (Computer-aided Engine-Pump Control system) Main pumps regulated by electronic engine-speed sensing control system. Optimum operation mode selectable among 3 power modes depending on type of job.
- OHS (Optimum Hydraulic System) assures fully independent and combined operations.
- FPS (Fuel-saving Pump System)
- Auto-idling system.
- Quick-auto-idling system.
- High-pressure 2-speed travel system for high traction force and travel speed.
- Forced-cooling pump drive system.
- TIG (Tungsten Insert Gas) welding pipings.

Main pumps 3 variable-displacement, swash plate
 type axial piston pumps
 Main. oil flow ... 3 x 495 L/min
 (3 x 130.8 US gpm, 3 x 108.9 Imp gpm)
 Pilot pump Gear pump
 Max. oil flow 63.0 L/min (16.6 US gpm, 13.9 Imp gpm)

Relief Valve Settings

Boom/arm/bucket
 circuit 31.4 MPa (320 kgf/cm², 4 550 psi)
 Swing circuit 29.4 MPa (300 kgf/cm², 4 270 psi)
 Travel circuit 31.4 MPa (320 kgf/cm², 4 550 psi)
 Pilot circuit 5.2 MPa (53 kgf/cm², 650 psi)

Hydraulic Cylinders

High-strength piston rods and tubes adopted. Cylinder cushion mechanisms are provided for boom, arm, bucket and dump cylinders.
 Bucket cylinder of loading shovel is provided with protector.

Dimensions

Backhoe	Quan.	Bore	Rod diameter
Boom	2	230 mm (9.1")	160 mm (6.3")
Arm	1	260 mm (10.2")	180 mm (7.1")
Bucket	1	230 mm (9.1")	160 mm (6.3")

Loading shovel

	Quan.	Bore	Rod diameter
Boom	2	230 mm (9.1")	160 mm (6.3")
Arm	1	215 mm (8.5")	150 mm (5.9")
Bucket	2	200 mm (7.9")	150 mm (5.9")
Dump	2	140 mm (5.5")	85 mm (3.3")
Level	1	230 mm (9.1")	160 mm (6.3")

Hydraulic Filters

All hydraulic circuits have high-quality hydraulic filters for protection against oil contamination and longer life of hydraulic components.

	Qty.	
Full flow filter	2	10 μm
Drain filter	1	10 μm
(For all plunger type pumps & motors)		
Suction filter	2	177 μm
Pilot filter	1	10 μm

These filters are centralized in arrangement for facilitating maintenance.

CONTROLS

2 Implement Levers

Remote-controlled joystick hydraulic servo system. Right lever is for boom and bucket control, left lever for swing and arm control. For loading shovel, 2 pedals provided for opening/closing the bottom dump bucket.

2 Travel Levers with Pedals

Remote-controlled hydraulic servo system. Independent drive at each track allows counter rotation of tracks.

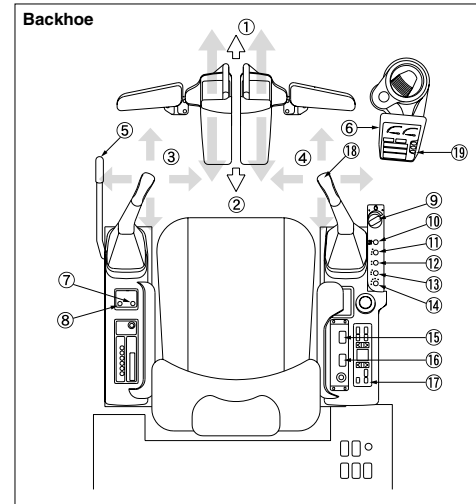

- ① Travel Forward
- ② Travel Reverse
- ③ Swing/Arm Control Lever
- ④ Boom/Bucket Control Lever
- ⑤ Pilot Control Shut-off Lever
- ⑥ Monitor Panel
- ⑦ Engine Preheat Switch
- ⑧ Entrance Light Switch
- ⑨ Engine Control Dial
- ⑩ Auto Idling Switch
- ⑪ Power Mode Switch
- ⑫ Travel Mode Switch
- ⑬ Work Light Switch
- ⑭ Wiper Washer Switch
- ⑮ Boom Mode Selector Switch
(Comfortable Mode / Powerful Mode)
- ⑯ Heavy Lifting Switch
- ⑰ Air Conditioner Switch
- ⑱ Quick Idling Switch
- ⑲ Auto-Lubrication Switch

UPPERSTRUCTURE

Revolving Frame

A deep, full-reinforced box section. Heavy-gauge steel plates used for ruggedness.

Deck Machinery

Maintenance accessibility is the major feature in the layout of deck machinery. Sidewalks provide easy access to engines, hydraulic and electrical components.

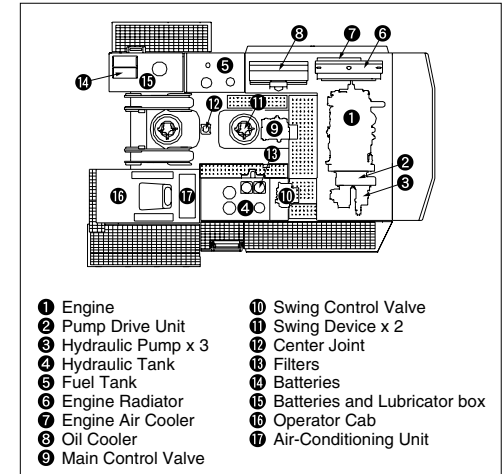

Swing Mechanism

2 high-torque, axial-piston motors with planetary reduction gear bathed in oil. Swing circle is single-row, shear-type ball bearing with induction-hardened internal gear. Internal gear and pinion gear immersed in lubricant. Swing parking brake is spring-set, hydraulic-released disc type.

Swing speed 5.8 min⁻¹ (rpm)

Operator's Cab

Steel construction with integrated, falling-object-protective structure meeting SAE FOPS. Independent, pressurized, 1 100 mm (3'7") wide, 1 900 mm (6'3") high, roomy 3.46 m³ (4.53 yd³) cab with tinted-glass windows features all-round visibility. Spring-suspension-type, fully-adjustable reclining seat with armrests; movable with or without front and swing control levers by slide. Instrument and control panel is built in cab wall is in easy range of the operator.

Powerful fresh air ventilation type air conditioner. Cool-and-hot box and rotatable blower louvers also serve as defrosters. Thus, rapid air-conditioning can be achieved for operator comfort. Fluid-filled elastic-mounting and sound-proofing structure to reduce noise level and vibration.

Noise level 78 dB(A) in the cab; on max.
 engine speed under no-load condition.



LOADING SHOVEL ATTACHMENTS

Boom and arm are all-welded, low-stress, high-tensile strength steel full-box section design. Efficient, automatic level crowding achieved by one-lever control because parallel link mechanism keeps the bucket digging angle constant, and level cylinder circuit maintains the bucket height constant. (Auto-Leveling Crowd Mechanism)

- Dual-support-type boom/arm/bucket pin linkage
- Double lip pin seals plus O-ring with protector ring at arm top.



WORKING RANGES

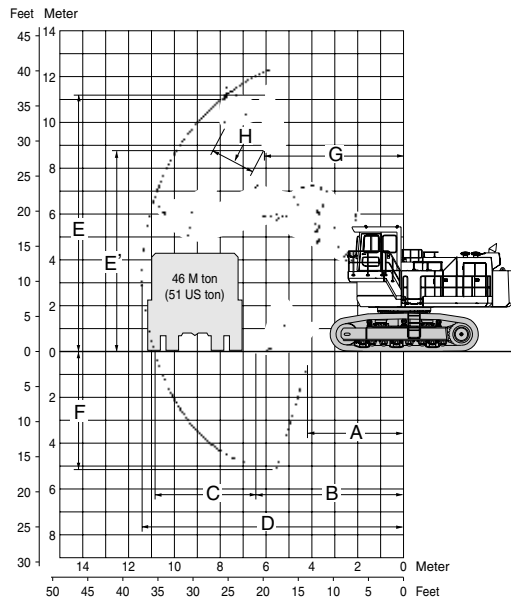

	Bottom dump type
A Min. digging distance	4 460 mm (14'8")
B Min. level crowding distance	6 520 mm (21'5")
C Level crowding distance	4 340 mm (14'3")
D Max. digging reach	11 440 mm (37'6")
E Max. cutting height	12 350 mm (40'6")
E' Max. dumping height	8 740 mm (28'8")
F Max. digging depth	5 240 mm (17'2")
G Working radius at max. dumping height	6 090 mm (20'0")
H Max. bucket opening width	1 880 mm (6'2")
Crowding force	583 kN (59 400 kgf, 131 000 lbf)
Breakout force	589 kN (60 100 kgf, 132 500 lbf)

Bucket (PCSA heaped 2:1)

Capacity	Width	No. of teeth	Weight	Type	Materials density
5.9 m ³ (7.7 yd ³)	2 510 mm (8'3")	6	9 780 kg (21 600 lb)	●	1 800 kg/m ³ (3 030 lb/yd ³)
6.5 m ³ (8.5 yd ³)	2 700 mm (8'10")	6	9 200 kg (20 300 lb)	◎	1 800 kg/m ³ (3 030 lb/yd ³)

- : Bottom dump type rock bucket
- ◎: Bottom dump type general purpose bucket



STANDARD EQUIPMENT Standard equipment may vary by country, so please consult your Hitachi dealer for details.

ENGINE

- S/P model control
- E mode control
- 80 A alternator
- Dry-type air filter with clean dust cup
- Cartridge-type engine oil filter
- Cartridge-type fuel filter
- Water filter
- Radiator and air cooler with dust protective net
- Radiator reserve tank
- Fan guard
- Isolation-mounted engine
- Auto-idle system
- Quick-idle system
- Overheat prevention device

HYDRAULIC SYSTEM

- E-P control system
- OHS (Optimum Hydraulic System)
- FPS (Fuel-saving Pump System)
- Heavy lifting system
- Boom mode selector system
- Forced-lubrication and forced cooling pump drive system
- Control valve with main relief valve
- Suction filter
- Full-flow filter
- Pilot filter
- Pump drain filter

CAB

- All-weather sound-suppressed steel integrated cab with headguard (meeting SAE FOPS), laminated glass windshield, reinforced/tinted (bronze color) glass front and side and rear windows, intermittent wiper interlocked with front windshield washer, adjustable reclining seat with adjustable armrests, footrest, electrical horn, auto-tuning AM-FM radio with digital clock, seat belt, cigarette lighter, ashtray, parcel pocket, glove compartment, floor mat, auto-idle switch, sun visor, evacuation hammer, preheat switch, auto air conditioner with defroster, hot and cool box, engine control dial, and pilot control shut-off lever.

MONITOR SYSTEMS

- Meters:
 - Hourmeter and trip-meter, engine coolant temperature gauge and fuel gauge, auto-idle, quick-idle indicator, lubrication mode indicator.

Warning indicators:

- Radiator water level, engine oil level, hydraulic oil level, fuel level, auto lubrication, air-filter restriction, pump transmission oil pressure, alternator, exhaust temp, over heat, engine oil pressure, engine stop, work light, preheat, and engine warning
- Hour meter and trip-meter select switch
- Reset switch
- Lubrication mode select switch

DATA LOGGING SYSTEM

- DLU (Data-logging unit) continuously records performance of the engine and the hydraulic system. The record can be down-loaded by lap top PC.

LIGHTS

- 4 working lights, 2 cab lights
- 1 entrance light

UPPERSTRUCTURE

- Undercover
- 1 75 000 kg (38 580 lb) counterweight
- Electric grease gun with hose reel
- Centralized lubrication system for swing bearing
- Control valves with main relief valves and port relief valves
- Slow return orifices and make up valves for cylinder circuits

UNDERCARRIAGE

- Spring-set/hydraulic-released disc type parking brake
- Hydraulic (grease) track adjuster with shock absorbing recoils spring
- Travel motor cover
- Track and idler guards

MISCELLANEOUS

- Standard tool kit
- ISO-meeted stairs and handrails
- Wide side walk
- Auto-lubrication system for front-attachment
- 12 V power terminal board
- Slip resistance tapes
- Elevated Cab (for Loading Shovel)



OPTIONAL EQUIPMENT Optional equipment may vary by country, so please consult your Hitachi dealer for details.

- Travel motion alarm device
- High cab kit (for Backhoe)
- Full track guard

TRANSPORTATION

SuperEX

- Easily assembled owing to local assembling system requiring no welding.
- Overall width of below 3 500 (11'6") during transportation.

Unit: mm(ft in)

UPPERSTRUCTURE

Upperstructure

Weight : 33 900 kg (74 700 lb)

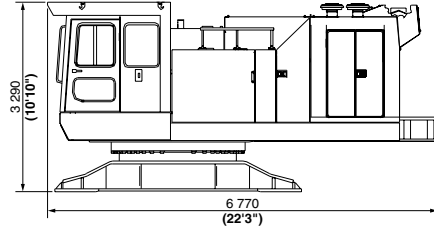

Counterweight

Weight : 17 500 kg (38 600 lb)



Width : 3 450 (11'4")

Width : 3 500 (11'6")

Side step

Weight : 21 kg (46 lb)

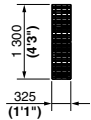

Width : 110 (4")

Side walk for Backhoe

Weight : 217 kg (478 lb)

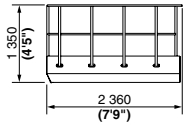

Width : 1 020 (3'4")

Side walk for Loading shovel

Weight : 180 kg (397 lb)

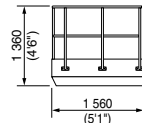

Width : 1 050 (3'5")

High cab kit for Loading shovel (Optional equipment for Backhoe)

Weight : 590 kg (1 300 lb)

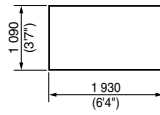

Width : 1 100 (3'7")

Step for loading shovel

Weight : 145 kg (320 lb)

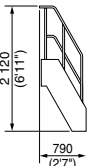

Width : 1 050 (3'5")

Side walk

Weight : 253 kg (558 lb)

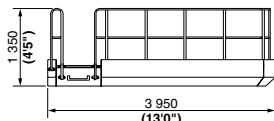

Width : 796 (2'7")

Side walk

Weight : 181 kg (400 lb)

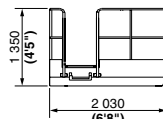

Width : 835 (2'9")

Side walk

Weight : 18 kg (40 lb)

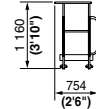

Width : 192 (7.6")

Handrail

Weight : 264 kg (582 lb)

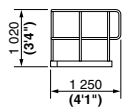

Width : 680 (2'3")

Handrail

Weight : 46 kg (101 lb)

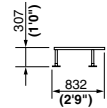

Width : 50 (0'2")

Radiator cover

Weight : 93 kg (205 lb)

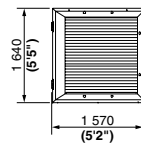

Width : 100 (3.9")

Oil cooler cover

Weight : 85 kg (187 lb)

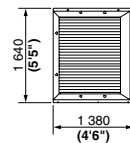

Width : 100 (3.9")

Unit: mm(ft in)

UNDERCARRIAGE

Side frame

Weight : 14 600 kg (32 200 lb) x 2

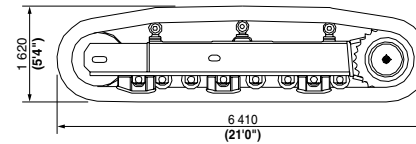

Width : 710 (2'4")

Traction device cover

Weight : 24 kg (53 lb) x 2



Width : 330 (1'1")

Steps

Weight : 18 kg (40 lb) x 2

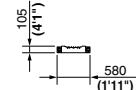

Width : 125 (2'9")

Ladder

Weight : 20 kg (44 lb)

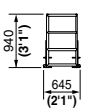

Width : 300 (11.9")

LOADING SHOVEL ATTACHMENTS

Bucket

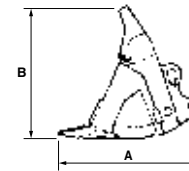

Bucket capacity	A	B	Max. Width	Weight
	mm (ft in)	mm (ft in)	mm (ft in)	kg (lb)
5.9 m ³ (7.7 yd ³)	2 770 (9'1")	2 480 (8'2")	2 690 (8'10")	9 780 kg (21 600 lb)
6.5 m ³ (8.5 yd ³)	2 770 (9'1")	2 680 (8'10")	2 890 (9'6")	9 200 kg (20 300 lb)

Boom & arm assembly

Weight : 15 200 kg (33 520 lb)

Width : 1 620 (5'4")

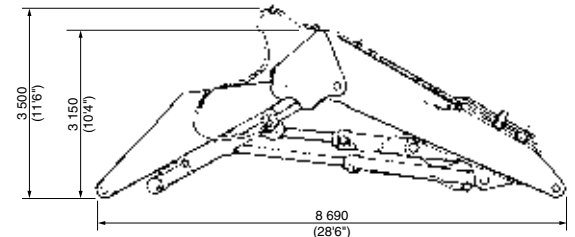

Boom Cylinders

Weight : 1 170 kg (2 580 lb)

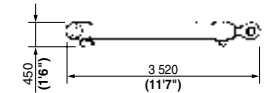

OVERALL

LOADING SHOVEL

Weight : 111 000 kg (244 800 lb)

Width : 5 470 (17'11")

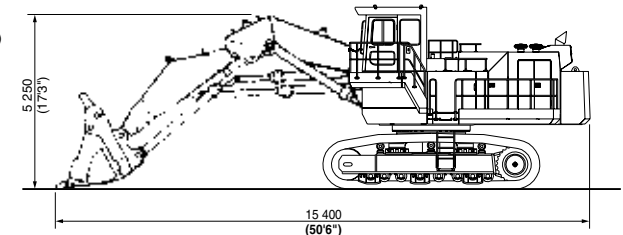

Unit: mm(ft in)

BACKHOE ATTACHMENTS

Boom

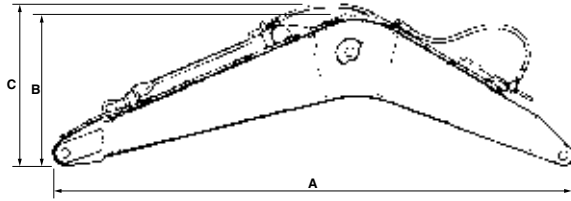

	Boom length	A	B	C	Width	Weight
EX1200-sc	9.1 m (29'10")	9 500 mm (31'2")	2 810 mm (9'3")	3 100 mm (10'2")	1 460 mm (4'9")	9 660 kg (21 300 lb)
EX1200-sc BE-boom	7.55 m (24'9")	7 960 mm (16'3")	3 150 mm (10'4")	3 400 mm (11'2")	1 460 mm (4'9")	9 080 kg (20 020 lb)

Boom cylinders

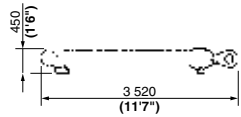

Weight : 1 170 kg (2 580 lb) x 2

Arm

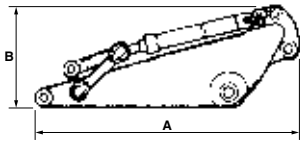

	Arm length	A	B	Width	Weight
EX1200-sc	3.4 m (11'2")	4 830 mm (15'10")	1 850 mm (6'1")	960 mm (3'2")	5 970 kg (13 160 lb)
	4.5 m (14'9")	5 975 mm (19'7")	1 700 mm (5'7")	960 mm (3'2")	6 300 kg (13 890 lb)
	5.8 m (19'0")	7 200 mm (23'8")	1 750 mm (5'9")	985 mm (3'3")	5 930 kg (13 070 lb)
EX1200-sc BE-boom	3.4 m (11'2")	4 880 mm (16'0")	1 850 mm (6'1")	960 mm (3'2")	6 100 kg (13 450 lb)

Bucket

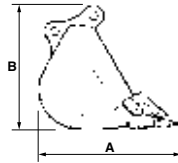

Capacity		A	B	Width	Weight	Type
PCSA heaped	CECE heaped					
3.0 m ³ (3.92 yd ³)	2.7 m ³	1 890 mm (6'2")	2 310 mm (7'7")	1 800 mm (5'11")	3 100 kg (6 830 lb)	●
3.4 m ³ (4.45 yd ³)	3.0 m ³	1 890 mm (6'2")	2 310 mm (7'7")	1 940 mm (6'4")	3 250 kg (7 170 lb)	◎
3.5 m ³ (4.58 yd ³)	3.2 m ³	2 300 mm (7'7")	2 480 mm (8'2")	1 460 mm (4'9")	4 300 kg (9 480 lb)	●
3.6 m ³ (4.71 yd ³)	3.2 m ³	2 280 mm (7'6")	2 240 mm (7'4")	1 600 mm (5'3")	4 030 kg (8 880 lb)	◎
4.0 m ³ (5.23 yd ³)	3.6 m ³	2 280 mm (7'6")	2 480 mm (8'2")	1 720 mm (5'8")	4 160 kg (9 170 lb)	◎
4.5 m ³ (5.89 yd ³)	4.0 m ³	2 280 mm (7'6")	2 480 mm (8'2")	1 900 mm (6'3")	4 300 kg (9 480 lb)	◎
4.5 m ³ (5.89 yd ³)	4.0 m ³	2 300 mm (7'7")	2 480 mm (8'2")	1 810 mm (5'11")	4 650 kg (10 250 lb)	●
5.0 m ³ (6.54 yd ³)	4.4 m ³	2 460 mm (8'1")	2 250 mm (7'5")	2 100 mm (6'11")	4 490 kg (9 900 lb)	◎
5.0 m ³ (6.54 yd ³)	4.4 m ³	2 560 mm (8'5")	2 280 mm (7'6")	1 960 mm (6'5")	5 460 kg (12 040 lb)	●
5.6 m ³ (7.32 yd ³)	4.9 m ³	2 460 mm (8'1")	2 250 mm (7'5")	2 240 mm (7'4")	4 720 kg (10 400 lb)	◎
5.6 m ³ (7.32 yd ³)	4.9 m ³	2 630 mm (8'8")	2 260 mm (7'5")	2 240 mm (7'4")	6 510 kg (14 350 lb)	●
6.0 m ³ (7.85 yd ³)	5.2 m ³	2 710 mm (8'11")	2 240 mm (7'4")	2 280 mm (7'6")	6 170 kg (13 600 lb)	◎
6.5 m ³ (8.50 yd ³)	5.7 m ³	2 710 mm (8'11")	2 240 mm (7'4")	2 310 mm (7'7")	6 350 kg (14 000 lb)	◎
7.1 m ³ (9.29 yd ³)	6.4 m ³	2 940 mm (9'8")	2 240 mm (7'4")	2 500 mm (8'2")	6 680 kg (14 730 lb)	◎

●: Rock bucket ◎: General purpose bucket

Unit: mm(ft in)

OVERALL

Backhoe

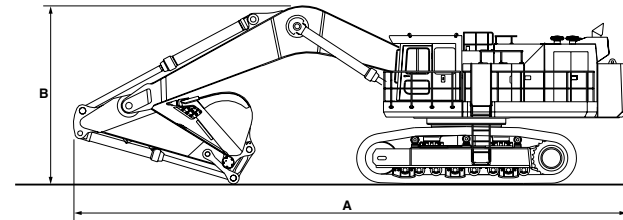

	A	B	Width
EX1200-sc	16 170 mm (53'1")	5 720 mm (18'9")	5 470 mm (17'11")
EX1200-sc BE-boom	14 620 mm (48'0")	6 400 mm (21'0")	5 470 mm (17'11")

LIFTING CAPACITIES

SuperEX

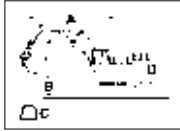

A: Load radius
B: Load point height
C: Lifting capacity

METRIC MEASURE

Rating over-side or 360 degrees Rating over-front Unit: 1 000 kg

Conditions	Load point height	Load radius												At max. reach		
		3 m		4 m		6 m		8 m		10 m		12 m		meter	meter	
EX1200-sc BE-boom 7.55 m BE-arm 3.4 m Bucket PCSA : 6.5 m ³ CECE : 5.7 m ³ Shoes 710 mm	8 m									*14.6	*14.6			*5.46	*5.46	12.6
	6 m									*16.1	*16.1			*6.19	*6.19	
	4 m									*17.1	*17.1			*6.21	*6.21	
	2 m									*19.2	*19.2			*6.56	*6.56	
	0 (Ground)									*20.7	*20.7			*7.62	*7.62	
	-2 m									*21.7	*21.7			*8.48	*8.48	
	-4 m									*20.4	*20.4			*10.6	*10.6	
	-6 m									*17.3	*17.3					

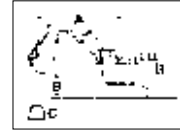

A: Load radius
B: Load point height
C: Lifting capacity

METRIC MEASURE

Rating over-side or 360 degrees Rating over-front Unit: 1 000 kg

Conditions	Load point height	Load radius												At max. reach							
		4 m		6 m		8 m		10 m		12 m		14 m		meter	meter						
EX1200-sc Boom 9.1 m Arm 4.5 m Bucket PCSA : 4.0 m ³ CECE : 3.6 m ³ Shoes 710 mm	10 m														*10.2	*10.2		*5.24	*5.24	14.6	
	8 m														*11.1	*11.1		*5.87	*5.87		
	6 m														*11.5	*11.5		*5.07	*5.07	15.4	
	4 m														*12.8	*12.8		*5.68	*5.68		
	2 m														*12.1	*12.1		*5.09	*5.09	15.9	
	0 (Ground)														*13.5	*13.5		*5.71	*5.71		
	-2 m																				
	-4 m																				
	-6 m																				
	-8 m																				

Conditions	Load point height	Load radius												At max. reach							
		3 m		4 m		6 m		8 m		10 m		12 m		meter	meter						
EX1200-sc Boom 9.1 m Arm 3.4 m Bucket PCSA : 5.0 m ³ CECE : 4.4 m ³ Shoes 710 mm	8 m														*8.88	*8.88		*9.64	*9.73	14.1	
	6 m															*15.2	*15.2		*8.54	*8.92	14.6
	4 m															*16.8	*16.8		*8.54	*9.77	
	2 m															*17.2	*17.2		*8.01	*9.21	14.8
	0 (Ground)															*19.0	*19.0		*16.3	*21.1	14.6
	-2 m															*21.1	*21.1		*16.3	*21.1	14.1
	-4 m														*20.5	*20.5		*15.5	*20.3	13.3	
	-6 m														*21.9	*21.9		*11.9	*11.9	11.9	
	-8 m														*31.1	*31.1		*28.3	*28.3		

With heavy lifting system

Notes: 1. Ratings are based on SAE J1097.
2. Lifting capacity of the EX Series does not exceed 75% of tipping load with the machine on firm, level ground or 87% full hydraulic capacity.
3. The load point is a hook (not standard equipment) loaded on the back of the bucket.
4. *Indicates load limited by hydraulic capacity.

Conditions	Load point height	Load radius												At max. reach									
		2 m		4 m		6 m		8 m		10 m		12 m		14 m		meter	meter						
EX1200-sc Boom 9.1 m Arm 5.8 m Bucket PCSA : 3.4 m ³ CECE : 3.0 m ³ Shoes 710 mm	8 m																	*9.25	*9.25	*4.38	*4.38	16.2	
	6 m																		*10.1	*10.1	*4.93	*4.93	16.7
	4 m																		*11.8	*11.8	*5.08	*5.08	16.8
	2 m																		*13.0	*13.0	*5.39	*5.39	16.7
	0 (Ground)																		*13.1	*13.1	*5.90	*5.90	16.3
	-2 m																		*14.5	*14.5	*6.69	*6.69	15.6
	-4 m																		*16.8	*16.8	*7.91	*7.91	14.5
	-6 m																		*17.8	*17.8	*9.13	*9.13	13.0
	-8 m																		*23.8	*23.8	*9.48	*9.48	10.8

With heavy lifting system

Notes: 1. Ratings are based on SAE J1097.
2. Lifting capacity of the EX Series does not exceed 75% of tipping load with the machine on firm, level ground or 87% full hydraulic capacity.
3. The load point is a hook (not standard equipment) loaded on the back of the bucket.
4. *Indicates load limited by hydraulic capacity.

Hitachi Construction Machinery Co., Ltd.

Head Office : 5-1, Koraku 2-chome, Bunkyo-ku,
Tokyo 112-8563, Japan

Telephone : Tokyo (03) 3830-8050

Facsimile : Tokyo (03) 3830-8202

KS-E377P

These specifications are subject to change without notice

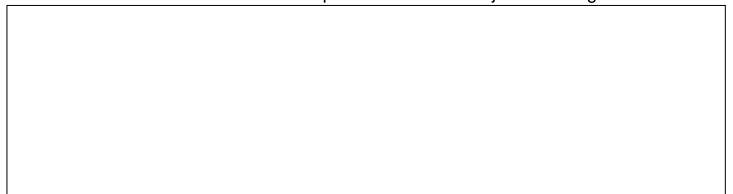

Printed in Japan 03.03(KA/KA,GT3)