

HITACHI

DASH 3



## ZAXIS 450LC-3

- Engine Rated Power: 348 SAE net hp (260 kW) @ 1,800 rpm
- Operating Weight: 106,180 lb. (48 163 kg)
- Backhoe Bucket: 3.06 cu. yd. (2.34 m<sup>3</sup>), 54 in. (1370 mm)

**Engine**

Type .....	Isuzu AH-6WG1XYS-A01 with turbocharger and air-to-air charge air cooler; meets EPA and CARB emission non-road regulations
Rated Power .....	348 SAE net hp (260 kW) @ 1,800 rpm
Cylinders.....	6
Displacement .....	957 cu. in. (15.681 L)
Maximum Net Torque .....	1,164 lb.-ft. (1580 Nm) @ 1,500 rpm
Cooling Fan.....	suction-type, hydraulic-driven, remote-mounted drive
Electrical System .....	24 volt with 50-amp alternator
Batteries (two 12 volt) .....	reserve capacity: 280 min.
Off-level capacity .....	70% (35 deg.)

**Hydraulic System**

Main Pumps .....	two variable-displacement axial-piston
Maximum Flow .....	2 x 100 gpm (2 x 379 L/min.)
Pilot Pump .....	one gear
Maximum Flow .....	7.9 gpm (30 L/min.)
Pressure Setting .....	566 psi (3900 kPa)
<b>System Operating Pressure</b>	
Implement Circuits .....	4,625 psi (31 900 kPa)
Travel Circuits .....	4,980 psi (34 300 kPa)
Swing Circuits .....	4,045 psi (27 900 kPa)
Power Boost .....	4,980 psi (34 300 kPa)
Oil Filtration .....	one 10-micron full-flow return filter with by-pass / one pilot oil filter

**Cylinders**

	<b>Bore</b>	<b>Rod Diameter</b>	<b>Stroke</b>
Boom (2) .....	6.7 in. (170 mm)	4.5 in. (115 mm)	62.6 in. (1590 mm)
Arm (1).....	7.5 in. (190 mm)	5.1 in. (130 mm)	76.4 in. (1940 mm)
Bucket (1).....	6.7 in. (170 mm)	4.7 in. (120 mm)	52.2 in. (1325 mm)

**Swing Mechanism**

Swing Speed.....	0-9 rpm
Swing Torque .....	107,004 lb.-ft. (145 189 Nm)

**Undercarriage**

Carrier Rollers (per side) .....	3
Track Rollers (per side) .....	9
Shoes, Triple Semi-Grouser (per side) .....	53
Track Guides.....	front and center
Track Adjustment .....	hydraulic

**Travel Speed**

Low .....	0-2.1 mph (0-3.4 km/h)
High.....	0-3.4 mph (0-5.5 km/h)
Drawbar Pull.....	79,590 lb. (36 100 kg)

**Ground Pressure Data**

**Average Ground Pressure**

30-in. (750 mm) Triple Semi-Grouser Shoes (recommended for rocky terrain/stumps) .....	8.81 psi (60.7 kPa)
36-in. (900 mm) Triple Semi-Grouser Shoes (recommended for general/soft terrain).....	7.45 psi (51.4 kPa)

**SAE Operating Weights**

With Full Fuel Tank; 175-lb. (79 kg) Operator; 3.06-cu.-yd. (2.34 m³), 54-in. (1370 mm), 4,478-lb. (2031 kg) Bucket; 12-ft. 10-in. (3.9 m) Arm; 20,172-lb. (9150 kg) Counterweight; and 36-in. (900 mm) Triple Semi-Grouser Shoes .....106,180 lb. (48 163 kg)

**Capacities (U.S.)**

Fuel Tank .....	192 gal. (725 L)
Cooling System .....	50.7 qt. (48 L)
Engine Lubrication, Including Filter .....	59 qt. (55.8 L)
Hydraulic Tank .....	85 gal. (322 L)
Hydraulic System .....	148 gal. (560 L)
Propel Gearbox (each) .....	9 qt. (8.5 L)
Swing Drive .....	5 qt. (4.7 L)

**Component Weights**

**Undercarriage**

30-in. (750 mm) Triple Semi-Grouser Shoes .....	40,227 lb. (18 247 kg)
36-in. (900 mm) Triple Semi-Grouser Shoes .....	41,726 lb. (18 927 kg)
One-Piece Boom (with arm cylinder) .....	9,458 lb. (4290 kg)

**Arm with Bucket Cylinder and Linkage**

9 ft. 6 in. (2.9 m) .....	5,291 lb. (2400 kg)
With 20-ft. 7-in. (6.3 m) Mass-Excavating Boom .....	5,291 lb. (2400 kg)
11 ft. 2 in. (3.4 m) .....	5,137 lb. (2330 kg)
12 ft. 10 in. (3.9 m) .....	5,820 lb. (2640 kg)
16 ft. 1 in. (4.9 m) .....	4,078 lb. (1850 kg)

Boom Lift Cylinders (2) Total Weight .....	1,851 lb. (840 kg)
3.06-cu.-yd. (2.34 m³), 54-in. (1370 mm)	
General-Purpose Bucket .....	4,478 lb. (2031 kg)
Counterweight .....	20,172 lb. (9150 kg)

**Lifting Capacities**

**Italic** type indicates hydraulic-limited capacities; **lightface** type indicates stability-limited capacities, in lb. (kg). Ratings at bucket lift hook; machine equipped with 20,172-lb. (9150 kg) counterweight; standard gauge; and situated on firm, uniform supporting surface. Total load includes weight of cables, hook, etc. Figures do not exceed 87 percent of hydraulic capacities or 75 percent of weight needed to tip machine. All lift capacities are based on SAE J1097.

Load Point Height	10 ft. (3.05 m)		15 ft. (4.57 m)		20 ft. (6.10 m)		25 ft. (7.62 m)		30 ft. (9.15 m)	
	Over Front	Over Side	Over Front	Over Side	Over Front	Over Side	Over Front	Over Side	Over Front	Over Side
<i>With 23-ft. 0-in. (7.0 m) boom; 9-ft. 6-in. (2.9 m) arm; 3.0-cu.-yd. (2.3 m³), 3,924-lb. (1780 kg) bucket; and 30-in. (750 mm) triple semi-grouser shoes</i>										
25 ft. (7.62 m)							21,500 (9752)	21,500 (9752)		
20 ft. (6.10 m)							22,600 (10 251)	21,700 (9843)		
15 ft. (4.57 m)			39,900 (18 099)	39,900 (18 099)	29,600 (13 426)	29,600 (13 426)	24,700 (11 204)	20,800 (9435)	22,000 (9979)	15,000 (6804)
10 ft. (3.05 m)					34,800 (15 785)	28,000 (12 701)	27,300 (12 383)	19,800 (8981)	22,100 (10 024)	14,500 (6577)
5 ft. (1.52 m)					38,700 (17 554)	26,300 (11 930)	29,500 (13 381)	18,800 (8528)	23,800 (10 796)	14,000 (6350)
Ground Line					40,000 (18 144)	25,500 (11 567)	30,800 (13 971)	18,200 (8255)	23,300 (10 569)	13,600 (6169)
-5 ft. (-1.52 m)			49,400 (22 408)	40,500 (18 371)	39,000 (17 690)	25,200 (11 431)	30,500 (13 835)	17,900 (8119)	23,100 (10 478)	13,400 (6078)
-10 ft. (-3.05 m)	47,900 (21 727)	47,900 (21 727)	44,300 (20 094)	41,000 (18 597)	35,900 (16 284)	25,400 (11 521)	28,300 (12 837)	17,900 (8119)		
-15 ft. (-4.57 m)			36,500 (16 556)	36,500 (16 556)	29,900 (13 563)	26,000 (11 794)	22,600 (10 251)	18,400 (8346)		

*With 23-ft. 0-in. (7.0 m) boom; 11-ft. 2-in. (3.4 m) arm; 2.7-cu.-yd. (2.1 m³), 3,593-lb. (1630 kg) bucket; and 30-in. (750 mm) triple semi-grouser shoes*

20 ft. (6.10 m)							21,500 (9752)	21,500 (9752)	18,500 (8392)	15,900 (7212)
15 ft. (4.57 m)					28,000 (12 701)	28,000 (12 701)	23,700 (10 750)	21,400 (9707)	21,300 (9662)	15,500 (7031)
10 ft. (3.05 m)					33,400 (15 150)	29,000 (13 154)	26,500 (12 020)	20,400 (9253)	22,700 (10 297)	15,000 (6804)
5 ft. (1.52 m)					37,900 (17 191)	27,200 (12 338)	29,200 (13 245)	19,400 (8800)	24,100 (10 932)	14,400 (6532)
Ground Line			25,400 (11 521)	25,400 (11 521)	40,200 (18 235)	26,100 (11 839)	30,800 (13 971)	18,600 (8437)	23,700 (10 750)	14,000 (6350)
-5 ft. (-1.52 m)			43,200 (19 595)	40,700 (18 461)	40,100 (18 189)	25,600 (11 612)	31,100 (14 107)	18,200 (8255)	23,400 (10 614)	13,700 (6214)
-10 ft. (-3.05 m)	38,800 (17 600)	38,800 (17 600)	48,200 (21 863)	41,100 (18 643)	37,700 (17 101)	25,600 (11 612)	29,600 (13 426)	18,100 (8210)	23,100 (10 478)	13,700 (6214)
-15 ft. (-4.57 m)	49,300 (22 362)	49,300 (22 362)	41,100 (18 643)	41,100 (18 643)	32,800 (14 878)	26,100 (11 839)	25,500 (11 567)	18,500 (8392)		
-20 ft. (-6.10 m)			29,600 (13 426)	29,600 (13 426)	23,400 (10 614)	23,400 (10 614)				

### Lifting Capacities

**Boldface italic** type indicates hydraulic-limited capacities; lightface type indicates stability-limited capacities, in lb. (kg). Ratings at bucket lift hook; machine equipped with 20,172-lb. (9150 kg) counterweight; standard gauge; and situated on firm, uniform supporting surface. Total load includes weight of cables, hook, etc. Figures do not exceed 87 percent of hydraulic capacities or 75 percent of weight needed to tip machine. All lift capacities are based on SAE J1097.

Load Point Height	10 ft. (3.05 m)		15 ft. (4.57 m)		20 ft. (6.10 m)		25 ft. (7.62 m)		30 ft. (9.15 m)	
	Over Front	Over Side	Over Front	Over Side	Over Front	Over Side	Over Front	Over Side	Over Front	Over Side
<i>With 23-ft. 0-in. (7.0 m) boom; 12-ft. 10-in. (3.9 m) arm; 2.5-cu.-yd. (1.9 m³), 5,434-lb. (1570 kg) bucket; and 30-in. (750 mm) triple semi-grouser shoes</i>										
25 ft. (7.62 m)									<b>11,200 (5080)</b>	<b>11,200 (5080)</b>
20 ft. (6.10 m)									<b>17,900 (8119)</b>	16,000 (7258)
15 ft. (4.57 m)								<b>22,100 (10 024)</b>	21,600 (9798)	<b>20,000 (9072)</b>
10 ft. (3.05 m)			<b>43,900 (19 913)</b>	<b>43,900 (19 913)</b>	<b>31,100 (14 107)</b>	29,300 (13 290)	25,000 (11 340)	20,400 (9253)	<b>21,500 (9752)</b>	14,900 (6759)
5 ft. (1.52 m)			<b>35,100 (15 921)</b>	<b>35,100 (15 921)</b>	<b>36,100 (16 375)</b>	27,300 (12 383)	<b>27,900 (12 655)</b>	19,300 (8754)	<b>23,100 (10 478)</b>	14,300 (6486)
Ground Line			<b>32,500 (14 742)</b>	<b>32,500 (14 742)</b>	<b>39,200 (17 781)</b>	25,900 (11 748)	<b>29,900 (13 563)</b>	18,400 (8346)	23,500 (10 660)	13,700 (6214)
-5 ft. (-1.52 m)	<b>19,400 (8800)</b>	<b>19,400 (8800)</b>	<b>44,000 (19 958)</b>	40,000 (18 144)	<b>39,800 (18 053)</b>	25,200 (11 431)	<b>30,700 (13 925)</b>	17,900 (8119)	23,100 (10 478)	13,400 (6078)
-10 ft. (-3.05 m)	<b>36,700 (16 647)</b>	<b>36,700 (16 647)</b>	<b>50,200 (22 770)</b>	40,200 (18 235)	<b>38,300 (17 373)</b>	25,100 (11 385)	<b>29,800 (13 517)</b>	17,700 (8029)	23,000 (10 433)	13,300 (6033)
-15 ft. (-4.57 m)	<b>56,100 (25 447)</b>	<b>56,100 (25 447)</b>	<b>43,900 (19 913)</b>	40,800 (18 507)	<b>34,300 (15 558)</b>	25,400 (11 521)	<b>26,800 (12 156)</b>	17,900 (8119)		
-20 ft. (-6.10 m)			<b>33,900 (15 377)</b>	<b>33,900 (15 377)</b>	<b>26,800 (12 156)</b>	26,200 (11 884)	<b>19,200 (8709)</b>	18,700 (8482)		

*With 23-ft. 0-in. (7.0 m) boom; 16-ft. 1-in. (4.9 m) arm; 1.8-cu.-yd. (1.4 m³), 2,579-lb. (1170 kg) bucket; and 30-in. (750 mm) triple semi-grouser shoes*

15 ft. (4.57 m)									<b>18,800 (8528)</b>	17,300 (7847)
10 ft. (3.05 m)								<b>23,600 (10 705)</b>	22,500 (10 206)	<b>20,900 (9480)</b>
5 ft. (1.52 m)			<b>48,100 (21 818)</b>	46,000 (20 865)	<b>34,000 (15 422)</b>	29,800 (13 517)	<b>27,000 (12 247)</b>	21,200 (9616)	<b>22,900 (10 387)</b>	15,900 (7212)
Ground Line			<b>42,900 (19 459)</b>	<b>42,900 (19 459)</b>	<b>38,600 (17 509)</b>	28,000 (12 701)	<b>29,900 (13 563)</b>	20,100 (9117)	<b>24,700 (11 204)</b>	15,200 (6895)
-5 ft. (-1.52 m)	<b>19,100 (8664)</b>	<b>19,100 (8664)</b>	<b>43,400 (19 686)</b>	41,600 (18 870)	<b>40,900 (18 552)</b>	26,900 (12 202)	<b>31,700 (14 379)</b>	19,400 (8800)	24,500 (11 113)	14,700 (6668)
-10 ft. (-3.05 m)	<b>30,000 (13 608)</b>	<b>30,000 (13 608)</b>	<b>53,900 (24 449)</b>	41,200 (18 688)	<b>41,100 (18 643)</b>	26,400 (11 975)	32,000 (14 515)	18,900 (8573)	24,100 (10 932)	14,500 (6577)
-15 ft. (-4.57 m)	<b>43,500 (19 731)</b>	<b>43,500 (19 731)</b>	<b>51,200 (23 224)</b>	41,500 (18 824)	<b>38,900 (17 645)</b>	26,300 (11 930)	<b>30,600 (13 880)</b>	18,900 (8573)	24,100 (10 932)	14,400 (6532)
-20 ft. (-6.10 m)	<b>58,800 (26 672)</b>	<b>58,800 (26 672)</b>	<b>44,000 (19 958)</b>	42,200 (19 142)	<b>34,100 (15 468)</b>	26,700 (12 111)	<b>26,600 (12 066)</b>	19,200 (8709)	<b>19,500 (8845)</b>	14,800 (6713)
-25 ft. (-7.62 m)			<b>31,900 (14 470)</b>	<b>31,900 (14 470)</b>	<b>24,700 (11 204)</b>	<b>24,700 (11 204)</b>				

*With 20-ft. 8-in. (6.3 m) ME boom; 9-ft. 6-in. (2.9 m) ME arm; 3.3-cu.-yd. (2.5 m³), 4,123-lb. (1870 kg) bucket; and 30-in. (750 mm) triple semi-grouser shoes*

20 ft. (6.10 m)					<b>25,400 (11 521)</b>	<b>25,400 (11 521)</b>	<b>22,500 (10 206)</b>	21,400 (9707)		
15 ft. (4.57 m)			<b>36,200 (16 420)</b>	<b>36,200 (16 420)</b>	<b>28,900 (13 109)</b>	<b>28,900 (13 109)</b>	<b>25,100 (11 385)</b>	20,800 (9435)		
10 ft. (3.05 m)			<b>33,700 (15 286)</b>	28,800 (13 064)	<b>27,300 (12 383)</b>	19,900 (9027)	<b>17,700 (8029)</b>	14,300 (6486)		
5 ft. (1.52 m)			<b>37,900 (17 191)</b>	27,000 (12 247)	<b>29,500 (13 381)</b>	19,000 (8618)	<b>22,700 (10 297)</b>	13,900 (6305)		
Ground Line			<b>55,100 (24 993)</b>	40,700 (18 461)	<b>39,900 (18 099)</b>	25,900 (11 748)	<b>30,700 (13 925)</b>	18,300 (8301)	<b>20,000 (9072)</b>	13,600 (6169)
-5 ft. (-1.52 m)			<b>51,800 (23 496)</b>	40,600 (18 416)	<b>39,200 (17 781)</b>	25,400 (11 521)	<b>30,200 (13 699)</b>	18,000 (8165)		
-10 ft. (-3.05 m)			<b>45,600 (20 684)</b>	41,100 (18 643)	<b>35,400 (16 057)</b>	25,600 (11 612)	<b>26,800 (12 156)</b>	18,100 (8210)		
-15 ft. (-4.57 m)			<b>35,000 (15 876)</b>	<b>35,000 (15 876)</b>	<b>27,000 (12 247)</b>	26,400 (11 975)				

*With 23-ft. 0-in. (7.0 m) boom; 9-ft. 6-in. (2.9 m) arm; 3.0-cu.-yd. (2.3 m³), 3,924-lb. (1780 kg) bucket; and 36-in. (900 mm) triple semi-grouser shoes*

25 ft. (7.62 m)									<b>21,500 (9752)</b>	<b>21,500 (9752)</b>
20 ft. (6.10 m)									<b>22,600 (10 251)</b>	21,900 (9934)
15 ft. (4.57 m)			<b>39,900 (18 099)</b>	<b>39,900 (18 099)</b>	<b>29,600 (13 426)</b>	<b>29,600 (13 426)</b>	<b>24,700 (11 204)</b>	21,100 (9571)	<b>22,000 (9979)</b>	15,300 (6940)
10 ft. (3.05 m)					<b>34,800 (15 785)</b>	28,400 (12 882)	<b>27,300 (12 383)</b>	20,000 (9072)	<b>23,100 (10 478)</b>	14,700 (6668)
5 ft. (1.52 m)					<b>38,700 (17 554)</b>	26,700 (12 111)	<b>29,500 (13 381)</b>	19,100 (8664)	24,100 (10 932)	14,200 (6441)
Ground Line					<b>40,000 (18 144)</b>	25,900 (11 748)	<b>30,800 (13 971)</b>	18,400 (8346)	23,700 (10 750)	13,800 (6260)
-5 ft. (-1.52 m)			<b>49,400 (22 408)</b>	41,100 (18 643)	<b>39,000 (17 690)</b>	25,600 (11 612)	<b>30,500 (13 835)</b>	18,100 (8210)	23,500 (10 660)	13,700 (6214)
-10 ft. (-3.05 m)	<b>47,900 (21 727)</b>	<b>47,900 (21 727)</b>	<b>44,300 (20 094)</b>	41,500 (18 824)	<b>35,900 (16 284)</b>	25,800 (11 703)	<b>28,300 (12 837)</b>	18,200 (8255)		
-15 ft. (-4.57 m)			<b>36,500 (16 556)</b>	<b>36,500 (16 556)</b>	<b>29,900 (13 563)</b>	26,400 (11 975)	<b>22,600 (10 251)</b>	18,700 (8482)		

*With 23-ft. 0-in. (7.0 m) boom; 11-ft. 2-in. (3.4 m) arm; 2.7-cu.-yd. (2.1 m³), 3,593-lb. (1630 kg) bucket; and 36-in. (900 mm) triple semi-grouser shoes*

20 ft. (6.10 m)									<b>21,500 (9752)</b>	<b>21,500 (9752)</b>	<b>18,500 (8392)</b>	16,100 (7303)
15 ft. (4.57 m)					<b>28,000 (12 701)</b>	<b>28,000 (12 701)</b>	<b>23,700 (10 750)</b>	21,700 (9843)	<b>21,300 (9662)</b>	15,800 (7167)		
10 ft. (3.05 m)					<b>33,400 (15 150)</b>	29,400 (13 336)	<b>26,500 (12 020)</b>	20,700 (9389)	<b>22,700 (10 297)</b>	15,200 (6895)		
5 ft. (1.52 m)					<b>37,900 (17 191)</b>	27,600 (12 519)	<b>29,200 (13 245)</b>	19,700 (8936)	<b>24,100 (10 932)</b>	14,700 (6668)		
Ground Line					<b>40,200 (18 235)</b>	26,500 (12 020)	<b>30,800 (13 971)</b>	18,900 (8573)	24,100 (10 932)	14,200 (6441)		
-5 ft. (-1.52 m)					<b>43,200 (19 595)</b>	41,300 (18 734)	<b>40,100 (18 189)</b>	26,000 (11 794)	<b>31,100 (14 107)</b>	18,500 (8392)	23,800 (10 796)	13,900 (6305)
-10 ft. (-3.05 m)	<b>38,800 (17 600)</b>	<b>38,800 (17 600)</b>	<b>48,200 (21 863)</b>	41,600 (18 870)	<b>37,700 (17 101)</b>	26,000 (11 794)	<b>29,600 (13 426)</b>	18,400 (8346)	<b>23,100 (10 478)</b>	14,000 (6350)		
-15 ft. (-4.57 m)	<b>49,300 (22 362)</b>	<b>49,300 (22 362)</b>	<b>41,100 (18 643)</b>	<b>41,100 (18 643)</b>	<b>32,800 (14 878)</b>	26,400 (11 975)	<b>25,500 (11 567)</b>	18,700 (8482)				
-20 ft. (-6.10 m)			<b>29,600 (13 426)</b>	<b>29,600 (13 426)</b>	<b>23,400 (10 614)</b>	<b>23,400 (10 614)</b>						

### Lifting Capacities

**Boldface italic** type indicates hydraulic-limited capacities; lightface type indicates stability-limited capacities, in lb. (kg). Ratings at bucket lift hook; machine equipped with 20,172-lb. (9150 kg) counterweight; standard gauge; and situated on firm, uniform supporting surface. Total load includes weight of cables, hook, etc. Figures do not exceed 87 percent of hydraulic capacities or 75 percent of weight needed to tip machine. All lift capacities are based on SAE J1097.

Load Point Height	10 ft. (3.05 m)		15 ft. (4.57 m)		20 ft. (6.10 m)		25 ft. (7.62 m)		30 ft. (9.15 m)		
	Over Front	Over Side	Over Front	Over Side	Over Front	Over Side	Over Front	Over Side	Over Front	Over Side	
<i>With 23-ft. 0-in. (7.0 m) boom; 12-ft. 10-in. (3.9 m) arm; 2.5-cu.-yd. (1.9 m³), 5,434-lb. (1570 kg) bucket; and 36-in. (900 mm) triple semi-grouser shoes</i>											
25 ft. (7.62 m)										<b>11,200 (5080)</b>	<b>11,200 (5080)</b>
20 ft. (6.10 m)										<b>17,900 (8119)</b>	16,200 (7348)
15 ft. (4.57 m)										<b>22,100 (10 024)</b>	21,900 (9934)
10 ft. (3.05 m)										<b>25,000 (11 340)</b>	20,700 (9389)
5 ft. (1.52 m)			<b>43,900 (19 913)</b>	<b>43,900 (19 913)</b>	<b>31,100 (14 107)</b>	29,700 (13 472)	<b>25,000 (11 340)</b>	19,600 (8891)	<b>23,100 (10 478)</b>	15,200 (6895)	
Ground Line			<b>32,500 (14 742)</b>	<b>32,500 (14 742)</b>	<b>39,200 (17 781)</b>	26,300 (11 930)	<b>29,900 (13 563)</b>	18,700 (8482)	23,900 (10 840)	14,000 (6350)	
-5 ft. (-1.52 m)	<b>19,400 (8800)</b>	<b>19,400 (8800)</b>	<b>44,000 (19 958)</b>	40,500 (18 371)	<b>39,800 (18 053)</b>	25,600 (11 612)	<b>30,700 (13 925)</b>	18,200 (8255)	23,500 (10 660)	13,600 (6169)	
-10 ft. (-3.05 m)	<b>36,700 (16 647)</b>	<b>36,700 (16 647)</b>	<b>50,200 (22 770)</b>	40,700 (18 461)	<b>38,300 (17 373)</b>	25,500 (11 567)	<b>29,800 (13 517)</b>	18,000 (8165)	23,400 (10 614)	13,500 (6124)	
-15 ft. (-4.57 m)	<b>56,100 (25 447)</b>	<b>56,100 (25 447)</b>	<b>43,900 (19 913)</b>	41,400 (18 779)	<b>34,300 (15 558)</b>	25,800 (11 703)	<b>26,800 (12 156)</b>	18,200 (8255)			
-20 ft. (-6.10 m)			<b>33,900 (15 377)</b>	<b>33,900 (15 377)</b>	<b>26,800 (12 156)</b>	26,500 (12 020)	<b>19,200 (8709)</b>	18,900 (8573)			

*With 23-ft. 0-in. (7.0 m) boom; 16-ft. 1-in. (4.9 m) arm; 1.8-cu.-yd. (1.4 m³), 2,579-lb. (1170 kg) bucket; and 36-in. (900 mm) triple semi-grouser shoes*

15 ft. (4.57 m)										<b>18,800 (8528)</b>	17,600 (7983)
10 ft. (3.05 m)										<b>23,600 (10 705)</b>	22,700 (10 297)
5 ft. (1.52 m)			<b>48,100 (21 818)</b>	46,600 (21 138)	<b>34,000 (15 422)</b>	30,100 (13 653)	<b>27,000 (12 247)</b>	21,500 (9752)	<b>22,900 (10 387)</b>	16,100 (7303)	
Ground Line			<b>42,900 (19 459)</b>	<b>42,900 (19 459)</b>	<b>38,600 (17 509)</b>	28,400 (12 882)	<b>29,900 (13 563)</b>	20,400 (9253)	<b>24,700 (11 204)</b>	15,500 (7031)	
-5 ft. (-1.52 m)	<b>19,100 (8664)</b>	<b>19,100 (8664)</b>	<b>43,400 (19 686)</b>	42,200 (19 142)	<b>40,900 (18 552)</b>	27,200 (12 338)	<b>31,700 (14 379)</b>	19,600 (8891)	24,800 (11 249)	15,000 (6804)	
-10 ft. (-3.05 m)	<b>30,000 (13 608)</b>	<b>30,000 (13 608)</b>	<b>53,900 (24 449)</b>	41,800 (18 960)	<b>41,100 (18 643)</b>	26,700 (12 111)	<b>32,000 (14 515)</b>	19,200 (8709)	24,500 (11 113)	14,700 (6668)	
-15 ft. (-4.57 m)	<b>43,500 (19 731)</b>	<b>43,500 (19 731)</b>	<b>51,200 (23 224)</b>	42,000 (19 051)	<b>38,900 (17 645)</b>	26,700 (12 111)	<b>30,600 (13 880)</b>	19,100 (8664)	<b>24,300 (11 022)</b>	14,700 (6668)	
-20 ft. (-6.10 m)	<b>58,800 (26 672)</b>	<b>58,800 (26 672)</b>	<b>44,000 (19 958)</b>	42,800 (19 414)	<b>34,100 (15 468)</b>	27,100 (12 292)	<b>26,600 (12 066)</b>	19,400 (8800)	<b>19,500 (8845)</b>	15,100 (6849)	
-25 ft. (-7.62 m)											

## Bucket Selection Guide\*

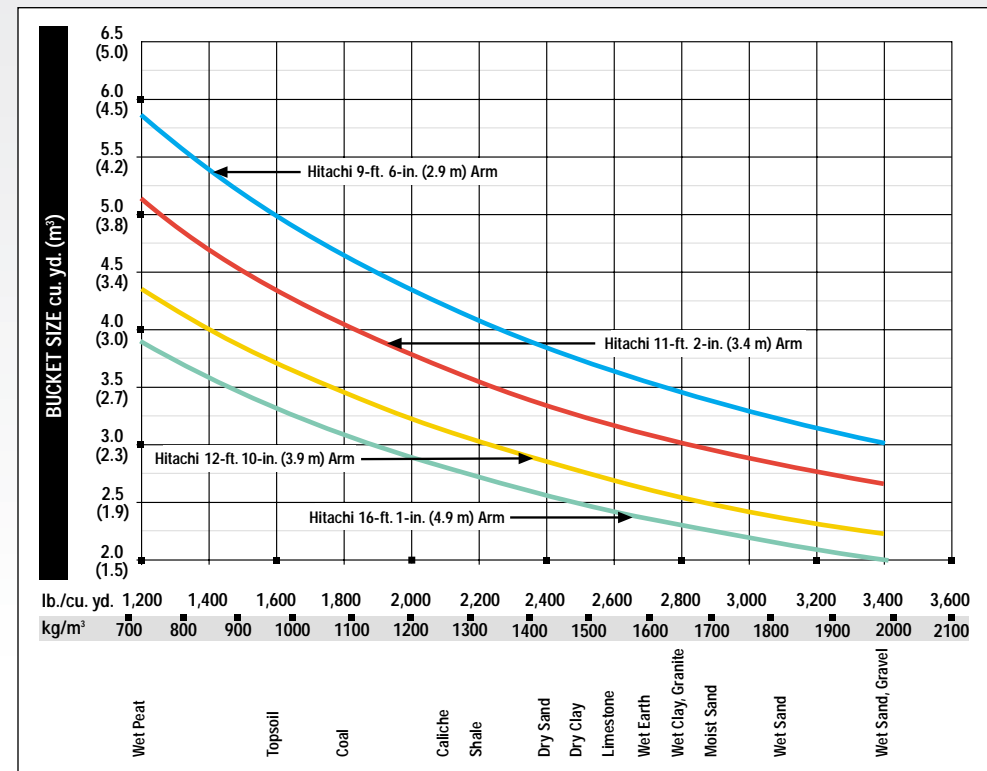

\*Contact your Hitachi dealer for optimum bucket and attachment selections. These recommendations are for general conditions and average use. Does not include optional equipment such as thumbs or couplers. Larger buckets may be possible when using light materials, for flat and level operations, less compacted materials, and volume loading applications such as mass excavation in ideal conditions. Smaller buckets are recommended for adverse conditions such as off-level applications, rocks, and uneven surfaces. Bucket capacity indicated is SAE heaped.

## Dimensions

<b>A</b> 9-ft. 6-in. (2.9 m) Arm .....11 ft. 10 in. (3.60 m)	<b>C</b> Operating Position.....9 ft. 6 in. (2.89 m)
11-ft. 2-in. (3.4 m) Arm .....11 ft. 5 in. (3.48 m)	Transport Position.....7 ft. 10 in. (2.39 m)
12-ft. 10-in. (3.9 m) Arm .....11 ft. 6 in. (3.50 m)	<b>D</b> 30-in. (750 mm) Triple Semi-Grouser Shoes
16-ft. 1-in. (4.9 m) Arm .....14 ft. 11 in. (4.55 m)	Operating Position .....11 ft. 11 in. (3.64 m)
20-ft. 7-in. (6.3 m) ME Boom	Transport Position .....10 ft. 4 in. (3.14 m)
with 9-ft. 6-in. (2.9 m) Arm .....12 ft. 3 in. (3.74 m)	36-in. (900 mm) Triple Semi-Grouser Shoes
<b>B</b> 9-ft. 6-in. (2.9 m) Arm .....39 ft. 4 in. (12.0 m)	Operating Position .....12 ft. 5 in. (3.79 m)
11-ft. 2-in. (3.4 m) Arm .....39 ft. 1 in. (11.91 m)	Transport Position .....10 ft. 10 in. (3.29 m)
12-ft. 10-in. (3.9 m) Arm .....39 ft. 1 in. (11.91 m)	
16-ft. 1-in. (4.9 m) Arm .....39 ft. 0 in. (11.9 m)	
20-ft. 7-in. (6.3 m) ME Boom	
with 9-ft. 6-in. (2.9 m) Arm .....36 ft. 10 in. (11.22 m)	

## ZAXIS 450LC-3

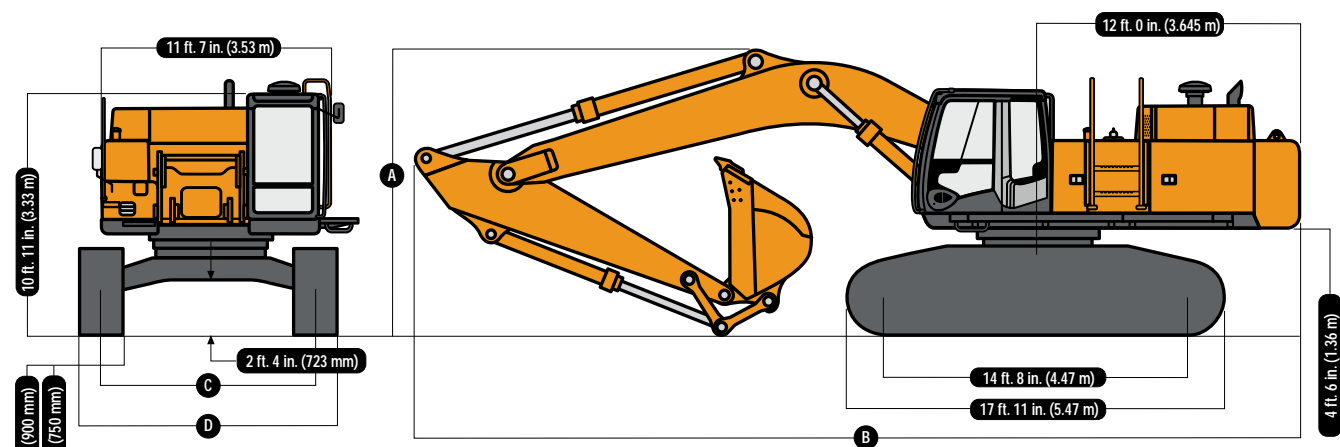

## Operating Information

	Arm Length 9 ft. 6 in. (2.9 m)	Arm Length 20-ft. 7-in. (6.3 m)	Arm Length 11 ft. 2 in. (3.4 m)	Arm Length 12 ft. 10 in. (3.9 m)	Arm Length 16 ft. 1 in. (4.9 m)
Arm Force with 36-in. (900 mm) Triple Semi-Grouser Shoes*	51,014 lb. (227 kN)	51,014 lb. (227 kN)	47,321 lb. (210 kN)	43,028 lb. (192 kN)	37,560 lb. (167 kN)
Bucket Digging Force with 36-in. (900 mm) Triple Semi-Grouser Shoes*	57,111 lb. (254 kN)	57,111 lb. (254 kN)	57,111 lb. (254 kN)	57,111 lb. (254 kN)	43,624 lb. (194 kN)
Lifting Capacity Over Front @ Ground Level.....20-ft. (6.1 m) Reach*	40,000 lb. (18 144 kg)	39,900 lb. (18 099 kg)	40,200 lb. (18 235 kg)	39,200 lb. (17 781 kg)	38,600 lb. (17 509 kg)
<b>A</b> Maximum Reach .....	37 ft. 5 in. (11.40 m)	35 ft. 8 in. (10.86 m)	39 ft. 7 in. (12.06 m)	41 ft. 0 in. (12.49 m)	43 ft. 9 in. (13.34 m)
<b>A'</b> Maximum Reach @ Ground Level.....	36 ft. 8 in. (11.17 m)	34 ft. 10 in. (10.61 m)	38 ft. 10 in. (11.84 m)	40 ft. 3 in. (12.28 m)	43 ft. 1 in. (13.14 m)
<b>B</b> Maximum Digging Depth .....	23 ft. 11 in. (7.28 m)	20 ft. 5 in. (6.23 m)	25 ft. 6 in. (7.77 m)	27 ft. 2 in. (8.27 m)	29 ft. 11 in. (9.11 m)
<b>B'</b> Maximum Digging Depth @ 8-ft. (2.44 m) Flat Bottom .....	23 ft. 3 in. (7.08 m)	19 ft. 11 in. (6.08 m)	25 ft. 0 in. (7.63 m)	26 ft. 8 in. (8.14 m)	29 ft. 6 in. (9.00 m)
<b>C</b> Maximum Cutting Height .....	33 ft. 8 in. (10.25 m)	35 ft. 8 in. (10.88 m)	36 ft. 3 in. (11.06 m)	36 ft. 7 in. (11.16 m)	38 ft. 6 in. (11.73 m)
<b>D</b> Maximum Dumping Height .....	23 ft. 1 in. (7.03 m)	24 ft. 1 in. (7.33 m)	25 ft. 1 in. (7.65 m)	25 ft. 6 in. (7.77 m)	28 ft. 5 in. (8.67 m)
<b>E</b> Minimum Swing Radius .....	16 ft. 6 in. (5.02 m)	12 ft. 11 in. (3.93 m)	15 ft. 10 in. (4.84 m)	15 ft. 9 in. (4.81 m)	15 ft. 11 in. (4.85 m)
<b>F</b> Maximum Vertical Wall .....	17 ft. 3 in. (5.27 m)	16 ft. 6 in. (5.02 m)	21 ft. 7 in. (6.59 m)	22 ft. 11 in. (6.98 m)	27 ft. 7 in. (8.42 m)
<b>G</b> Tail Swing Radius .....	12 ft. 0 in. (3.65 m)	12 ft. 0 in. (3.65 m)	12 ft. 0 in. (3.65 m)	12 ft. 0 in. (3.65 m)	12 ft. 0 in. (3.65 m)

\*Digging forces and lift capacities with power boost.

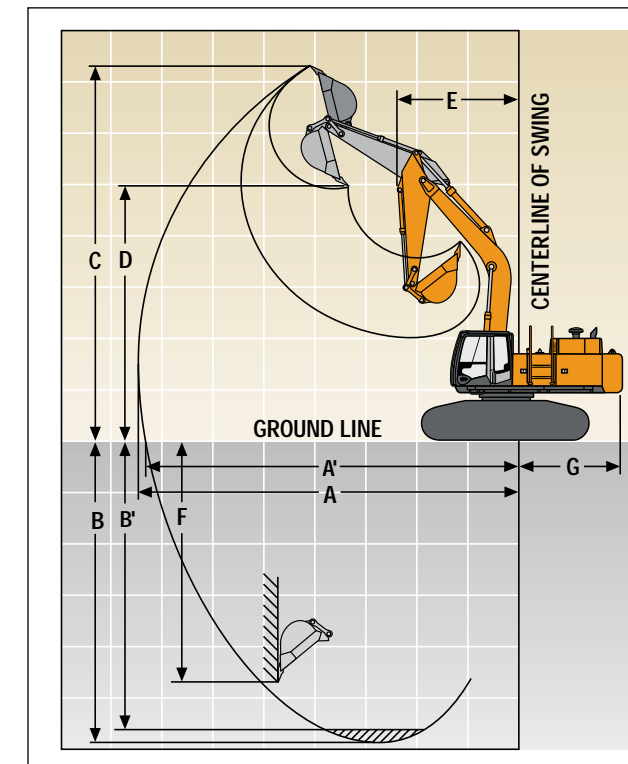

## Equipment

Key ● Standard Equipment ▲ Optional or Special Equipment

### Engine

- Meets EPA and CARB emission non-road regulations
- Auto-idle system
- Coolant recovery tank
- Dual-element dry-type air filter
- Electronic engine control
- Enclosed fan guard (conforms to SAE J1308)
- Engine coolant to -34°F (-37°C)
- Fuel filter with water separator
- Full-flow oil filter
- Turbocharger with charge air cooler
- Muffler, under hood, with vertical curved end exhaust stack
- Cool-on-demand hydraulic-driven fan
- Glow-plug start aid
- 500-hour engine-oil-change interval
- 70% (35 deg.) off-level capability
- ▲ Engine-oil-sampling valve
- ▲ Hydraulic fan reverser

### Hydraulic System

- Reduced-drift valve for boom down, arm in
- Auxiliary hydraulic valve section
- Spring-applied, hydraulically released automatic swing brake
- Auxiliary hydraulic-flow adjustments through monitor
- Auto power lift
- 5,000-hour hydraulic-oil-change interval
- ▲ Hydraulic-oil-sampling valve
- ▲ Auxiliary hydraulic lines
- ▲ Auxiliary pilot and electric controls
- ▲ Hydraulic filter restriction indicator kit
- ▲ Load-lowering control device
- ▲ Single-pedal propel control
- ▲ Pattern changer
- ▲ Hydraulic fan reverser

### Undercarriage

- Planetary drive with axial piston motors
- Propel motor shields
- Spring-applied, hydraulically released automatic propel brake
- Track guides, front idler and center
- Two-speed propel with automatic shift
- Upper carrier rollers (3)
- Sealed and lubricated track chain
- ▲ Triple semi-grouser shoes, 30 in. (750 mm)
- ▲ Triple semi-grouser shoes, 36 in. (900 mm)

### Upperstructure

- Counterweight-removal system
- Right- and left-hand mirrors
- Vandal locks with ignition key: Cab door / Fuel cap / Service doors / Toolbox
- Debris-screening side panel
- Service platform, left side
- Remote-mounted engine oil and fuel filters

### Front Attachments

- Bucket-to-arm clearance adjustable bushing (except ditching buckets)
- Centralized lubrication system
- Dirt seals on all bucket pins
- No-boom-arm option
- ▲ Boom, 23 ft. 0 in. (7.0 m)
- ▲ Boom, mass excavating, 20 ft. 8 in. (6.3 m)
- ▲ Arm, mass excavating, 9 ft. 6 in. (2.9 m)
- ▲ Arm, 9 ft. 6 in. (2.9 m)
- ▲ Arm, 11 ft. 2 in. (3.4 m)
- ▲ Arm, 12 ft. 10 in. (3.9 m)
- ▲ Arm, 16 ft. 1 in. (4.9 m)
- ▲ Attachment quick-couplers
- ▲ Boom cylinder with plumbing to mainframe for no-boom-arm option
- ▲ Buckets: Heavy duty / Heavy-duty high capacity / Side cutters and teeth
- ▲ Material clamps
- ▲ Super-long fronts

### Operator's Station

- Adjustable independent control positions (levers-to-seat, seat-to-pedals)
- AM/FM radio
- Auto climate control/air conditioner, 20,000 Btu/hr. (5.9 kW) with heater and pressurizer
- Built-in Operator's Manual storage compartment and manual
- Cell-phone power outlet, 12 volt, 60 watt, 5 amp
- Coat hook
- Deluxe air-suspension heated cloth seat with 4-in. (100 mm) adjustable armrests
- Floor mat
- Front windshield wiper with intermittent speeds
- Gauges (illuminated): Engine coolant / Fuel
- Horn, electric
- Hourmeter, electric
- Hydraulic shutoff lever, all controls
- Hydraulic warm-up control

- Interior light
- Large cup holder
- Machine Information Center (MIC)
- Mode selectors (illuminated): Power modes – three / Travel modes – two with automatic shift / Work mode – one / Boom mode
- Multifunction, color LCD monitor with: Diagnostic capability / Multiple-language capabilities / Maintenance tracking / Clock / Theft-deterrent system / System monitoring with alarm features: Auto-idle, engine air cleaner restriction indicator light, engine check, engine coolant temperature indicator light with audible alarm, engine oil pressure indicator light with audible alarm, low-alternator-charge indicator light, low-fuel indicator light, fault code alert indicator, fuel-rate display, wiper-mode indicator, work-lights-on indicator, and work-mode indicator
- Fluid-level switch and indicator light for engine coolant and engine oil
- ▲ Monitor system with alarm features: Hydraulic oil filter restriction indicator light
- Motion alarm with cancel switch (conforms to SAE J994)
- Power-boost switch on right console lever
- Propel pedals and levers
- SAE two-lever control pattern
- Seat belt, 2 in. (51 mm), retractable
- ▲ Seat belt, 3 in. (76 mm), non-retractable
- Tinted glass
- Transparent tinted overhead hatch
- Hot/cold beverage compartment
- ▲ 24- to 12-volt D.C. radio convertors, 10 amp
- ▲ Circulation fan
- ▲ Protection screens for cab front, rear, and side
- ▲ Window vandal protection covers

### Electrical

- 50-amp alternator
- Blade-type multi-fused circuits
- Positive terminal battery covers
- ▲ Cab extension wiring harness

### Lights

- Work lights: Halogen / One mounted on boom / One mounted on frame

## Control Owning and Operating Costs

Customer Personal Service (CPS) is part of Hitachi's proactive, fix-before-fail strategy on machine maintenance that will help control costs, increase profits, and reduce stress. Included in this comprehensive lineup of ongoing programs and services are:

**Fluid analysis program** – tells you what's going on inside all of your machine's major components so you'll know if there's a problem before you see a decline in performance. Fluid analysis is included in most extended coverage and preventive-maintenance agreements.

**Preventive Maintenance (PM) agreements** – give you a fixed cost for maintaining a machine for a given period of time. They also help you avoid downtime by ensuring that critical maintenance work gets done right and on schedule. On-site preventive maintenance service performed where and when you need it helps protect you from the expense of catastrophic failures and lets you avoid waste-disposal hassles.

**Extended coverage** – gives you a fixed cost for machine repairs for a given period of time so you can effectively manage expenses. Whether you work in a severe-service setting, or you just want to spread the risk

of doing business, this is a great way to custom-fit coverage to your operation. An extended coverage contract also travels well because it's backed by the company and is honored by all Hitachi dealers.

**Customer Support Advisors (CSAs)** – the CSA program lends a personal quality to Customer Personal Service (CPS). Certified CSAs have the knowledge and skills for helping make important decisions on machine maintenance and repair. Their mission is to help you implement a plan that's right for your business and take the burden of machine maintenance off your shoulders.

Net engine power is with standard equipment including air cleaner, exhaust system, alternator, and cooling fan, at standard conditions per SAE J1349 and DIN 6270B, using No. 2-D fuel at 35 API gravity. No derating is required up to 10,000-ft. (3050 m) altitude. Gross power is without cooling fan. Specifications and design subject to change without notice. Wherever applicable, specifications are in accordance with SAE standards. Except where otherwise noted, these specifications are based on a unit with 54-in. (1370 mm) bucket, 36-in. (900 mm) triple semi-grouser shoes, 20,172-lb. (9150 kg) counterweight, full fuel tank, and 175-lb. (79 kg) operator.